

Panasonic

Batteries - Create A New World



2002

**Valve Regulated
Lead-Acid Batteries**
Technical Handbook



VRLA

International English

Valve Regulated Lead-Acid Batteries: Table of Contents

| | |
|---|----|
| Precautions for Handling VRLA - Batteries | 4 |
| Overview | 13 |
| General Information on VRLA - Batteries | 14 |
| Characteristics | 17 |
| Charging Methods | 21 |
| Safety Design | 27 |
| Safety | 28 |
| Model Numbers of VRLA - Batteries | 29 |
| Battery Selection Chart | 31 |
| Battery Selection Guide | 33 |
| Standard Type | 34 |
| Trickle Long Life Type | 35 |
| Cycle Long Life Type | 37 |
| Individual Data Sheets | 38 |
| Terminal Data | 67 |
| Examples of Battery Labels | 68 |
| Glossary of Terms for VRLA - Batteries | 69 |

(notes)

1. This handbook is for specifying characteristics of storage batteries. Product prices, delivery terms and other details of business transactions are to be discussed with your representative.
2. Contents of this handbook are subject to change for improvement without prior notice to users. When considering use of the batteries described in this handbook, please confirm availability by contacting Panasonic.
3. For more details regarding MSE batteries, please refer to the separate technical handbook of "MSE Batteries." For more details regarding Super MSE batteries, please see "Super MSE Batteries" page in our "Short Form Catalog."

PRECAUTIONS FOR HANDLING VRLA-BATTERIES

Precautions for handling VRLA-Batteries

- This document should be read in its entirety and its contents fully understood before handling or using Panasonic rechargeable sealed Lead-Acid batteries. If there are any questions, please contact Panasonic. Please keep this document available for reference. Due to the potential energy stored in the batteries, improper handling or use of the batteries without understanding this document may result in injury caused by electrolyte leakage, heat generation, or explosion.

* All descriptions are subject to modification without notice.

Degree of danger

1. DANGER

When the batteries are handled or used improperly, death or severe injury may occur.

2. WARNING

When the batteries are handled or used improperly, death or severe injury may occur, and sight injury or loss of products often occur.

3. CAUTION

When the batteries are handled or used improperly, slight injury may occur and damage to the batteries and equipment may occur.

4. REQUEST

When the batteries are handled or used improperly, damage to quality or performance may occur.

Note (1): Improper handling and use of the batteries may cause dangerous conditions to arise. All precautions should be taken to prevent any harmful effects from the use of the batteries.

Note (2): "Severe injury" as a result of improper handling or use of the batteries may include but are not limited to loss of eyesight, injury/burn/electric shock/fracture of a bone/poisoning with after effect, or injury that requires long-term medical treatment. "Slight injury" covers such conditions as burns or electric shock that do not require long-term medical treatment. Damage to products is defined as extensive damage to a house, a house hold effects, a livestock, or pets.

Note (3): "Requests" are meant to prevent a decrease in the quality or the performance of the batteries.

INDEX

- Environments and Conditions
- Installation
- Preparation Prior to Operation
- Unspecified Use
- Methods of Handling and Operation
- Maintenance
- Treatment at Emergencies
- Storage
- Disposal and Recycling

PRECAUTIONS FOR HANDLING VRLA-BATTERIES-CONTINUED

Safety Precautions

1. Environment and Condition

DANGER

- (1) Do not put the batteries into airtight containers or bags. The batteries tend to generate inflammable gas upon excess charge which may cause an explosion if enclosed in an airtight container.

WARNING

- (1) The batteries must be charged using the specified charger or by maintaining the charging conditions indicated by Panasonic. If the batteries are charged under conditions other than those specified by Panasonic, they may leak, generate excessive heat, or explode.
- (2) When using the batteries in medical equipment, incorporate a back-up system other than the main battery in the event of power failure.
- (3) Insert insulation that is resistant to heat and sulfuric acid between the batteries and any metallic housing. Failure to do so may cause the batteries to smoke or burn in case of electrolyte leakage.
- (4) Do not place the batteries near a device that may generate sparks (such as a switch or fuse) and do not place the batteries close to fire. The batteries may generate an inflammable gas when charged excessively that may ignite upon contact with a spark or they may burn or explode due to sparks or fire.

CAUTION

- (1) Use or store the batteries in the temperature range specified below:
Discharge (operating in application): -15°C~50°C.
Charge: 0°C to 40°C.
Storage: -15°C to 40°C.
Temperatures above or below those recommended could result in damage or deformity of the batteries.
- (2) Avoid placing batteries near a heat-generating device (such as a transformer) which may cause the batteries to generate excessive heat, leak or explode.
- (3) Do not allow the batteries to be exposed to rain or sea water. If the battery terminals should get wet, they may corrode.
- (4) Do not use or store the batteries in a car under the blazing sun, in direct sunlight. To do so may cause the batteries to leak, generate excessive heat, or explode.
- (5) Do not use or store the batteries in a dusty place as dust may cause them to short between their terminals. When using the batteries in a dusty place, check them periodically.

PRECAUTIONS FOR HANDLING VRLA-BATTERIES-CONTINUED

- (6) In applications requiring more than one battery, first connect the batteries together and then connect the batteries to the charger or the load. Be careful to connect the (+) pole of the batteries to the (+) terminal of either the charger or the load. Improperly connecting the batteries, charger, or load may cause an explosion or fire to occur. In some cases, bodily injury may occur.
- (7) When handling the batteries, wear steel-tipped shoes to prevent possible injury to the feet if the batteries are accidentally dropped.

2. Installation

DANGER

- (1) Tools such as wrenches used to install the batteries should be insulated. Bare metal tools may cause an abnormal short circuit accident to occur resulting in bodily injury, damage to the batteries, explosion or fire.
- (2) Do not install the batteries in a room without ventilation. The batteries tend to generate an inflammable gas upon excess charge resulting in an explosion or fire if the room is closed.

WARNING

- (1) Do not contact any plastic or resin (*) which contains a migrating plasticizer with the batteries. Furthermore, avoid using organic solvents such as thinner, gasoline, lamp oil, benzine and liquid detergent to clean the batteries. The use of any of above materials may cause the containers and /or the covers (ABS resin) of the batteries to crack and leak. This may cause a fire in the worst scenario. Need to make sure the use of material will not cause the containers and/ or the covers (ABS resin) of the batteries to crack due to the migration of plasticizer within the material by asking the manufacturer of the material if necessary.

* Examples for plastic or resin which should be avoided using;
Vinyl chloride, Oily rubber.

* Examples for plastic or resin which is proper for the use;
Polyolefin resin such as polypropylene, polyethylene.

- (2) Always use such as rubber gloves when handling batteries with the voltages higher than 45 volts in order to prevent severe bodily injury from occurring.
- (3) Do not install the batteries in areas where they may come in contact with water. If the batteries come in contact with water, an electric shock or

REQUEST

- (1) Dropping a battery may cause a strong physical shock that may damage the performance of the battery.
- (2) Confirm the life of the batteries using the real load and charger. Differences in the charging and the discharging conditions may cause a big difference in the life of the batteries.

CAUTION

- (1) During unpacking, handle the batteries carefully and check for cracks, breakage, or electrolyte leakage. Failure to handle carefully may result in damage due to physical shock.
- (2) When the batteries are being mounted in the equipment, consider the best position for easy checking, maintenance and replacement. In addition, the batteries should be located in the lowest part of the equipment as possible. The Rechargeable Sealed Lead-Acid batteries, mentioned in this document, are designed for use in any position, but charging the batteries in the upside-down position should be avoided. When these batteries are charged excessively in the upside-down position, leakage of electrolyte from the rubber vents may occur. The upside-down is shown on the left side of the next drawings. In this upside-down position, the mark "Panasonic" on the battery are turned upside down. The drawings are only for explanation of the battery's position; therefore these are not equal to the real appearance of the battery that the specifications describe.
Can be used in the vertical position and the side-down position (maximum angle of 90 degrees from the normal position).
- (3) Do not carry the batteries by picking up them by their terminals or lead wires. To do so may damage the batteries.
- (4) Be careful not to jolt the batteries as it may result in damage to them.

PRECAUTIONS FOR HANDLING VRLA-BATTERIES-CONTINUED

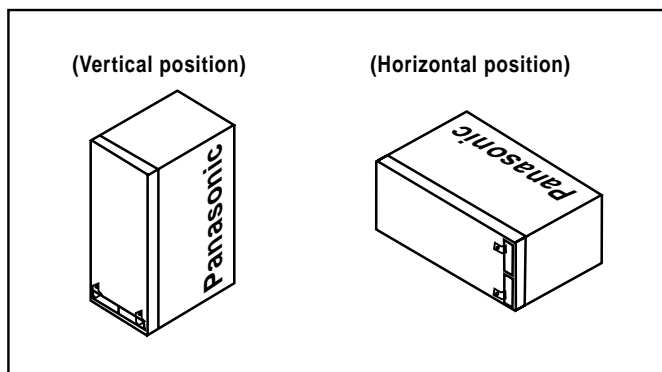
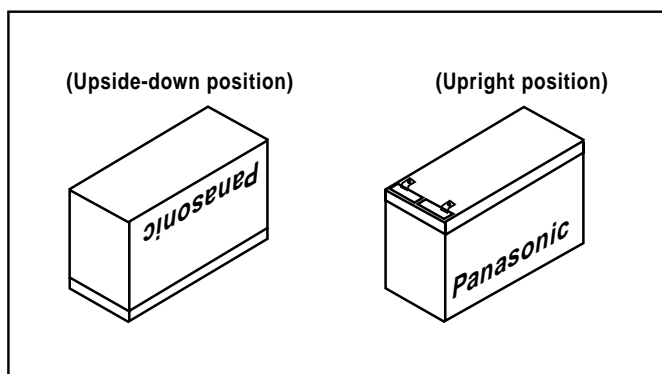

- (5) Be aware the batteries are relatively heavy compared to their volume. Not to be so may cause injury and/or lumbago.
- (6) Do not cover the batteries with plastic sheet as it may cause a fire or an explosion by conducting static electricity.

- (7) Fasten the bolts and the nuts with the torque as shown below: Not to do so may cause the battery terminals to spark and/or break.

| Bolt (nut) size (mm) | | | Fastening torque Nm |
|----------------------|-------|--------|---------------------|
| Diameter | Pitch | Length | |
| M5 (5) | 0.8 | 15 ± 1 | 2.0-3.1 |
| M6 (6) | 1.0 | 20 ± 1 | 4.1-5.6 |
| M8 (8) | 1.25 | 20 ± 1 | 8.2-10.2 |

- (8) Place the necessary insulating covers over the terminals, the connecting bars, and bolts and nuts to prevent a dangerous electric shock.
- (9) Please consult Panasonic prior to using the batteries in applications such as a motor bicycle, a engine driven lawn mower, etc. which may generate severe vibration.
- (10) Fasten the batteries firmly to the equipment to avoid the influence of vibration and/or physical shock.

REQUEST

- (1) The batteries should be installed by a certified technician.

PRECAUTIONS FOR HANDLING VRLA-BATTERIES-CONTINUED

3. Preparation Prior to Operation

DANGER

- (1) Be sure to provide enough insulation around the lead wires and/or plates used between the batteries and the application. Insufficient insulation may cause an electric shock heat generating from a short circuit(or excess current) may result in an injury, burn, smoke or fire.

CAUTION

- (1) Do not plug the batteries directly into the outlet or the cigarette receptacle of a car without inserting a charger between the batteries and the outlet or the receptacle. To do so may cause electrolyte leakage, heat generation, or explosion of the battery.
- (2) Turn off the circuit switch when the connections between the batteries and the charger/load are made.
- (3) When using the batteries for the first time, check for rust, heat generation, or -any other abnormalities. If found, do not use as it may cause electrolyte leakage, heat generation, or explosion.

REQUEST

- (1) Since the batteries tend to lose a part of their capacity due to self-discharge during shipment and storage, recharge the batteries before you use them after purchase or long-term storage in order to restore their full capacity. Check for the following conditions before to recharge:

| Charging method | Charging condition (at 20°C) |
|------------------|--|
| Constant voltage | <ul style="list-style-type: none"> Regulation range of the controlled voltage: 7.25V to 7.45V/6V battery, 14.5V to 14.9V/12V battery; Initial current: 0.1CA to 0.4CA; Maximum charging time: 24 hours. Short-time charge is possible when several batteries of the same model, under the same storage conditions can be charged in series. Otherwise they can be charged separately. |
| Constant current | <ul style="list-style-type: none"> Charging current: 0.1CA Charging time (hours)=[Amount of self- discharge (Ah)/0.1CA] x 120% Rough estimation of amount of self-discharge is as follows (for an example): When the storage ambient temperature is lower than 20°C, and storage time is known, assume the following amount of self-discharge:[5%/month] x storage months Multiply this by the rated capacity (at 20 hour rate) of the battery Regardless of the above calculation, the charge time for a refresh charge must be less than 12 hours. When the storage ambient temperature is higher than 20°C, please consult Panasonic. |

4. Unspecified Use

CAUTION

- (1) Do not place the batteries in an unspecified use or they may leak, generate heat, or explode.

PRECAUTIONS FOR HANDLING VRLA-BATTERIES-CONTINUED

5. Method of Handling and Operation

DANGER

- (1) Do not directly connect the positive and negative terminals with a conductive material such as a wire. Be careful while using a metal tool such as a wrench and/or carrying the batteries with metallic necklaces and hairpins not to make a short circuit. A short of the battery's terminals may cause heat generation, an explosion or a fire.
- (2) Charging the batteries with an inverse polarity connection between the batteries and the charger could cause electrolyte leakage, heat generation, or a fire.
- (3) Do not solder directly on the batteries' terminal tabs. Soldering directly on the batteries' terminals may cause a leak of electrolyte. Consult Panasonic when soldering is necessary.

WARNING

- (1) Never dispose of the batteries in a fire as it may cause them to explode or generate a toxic gas.
- (2) Do not attempt to disassemble the batteries as it could cause leakage of sulfuric acid that could bodily injure.
- (5) Avoid the use of the batteries differing in capacity, type, history of use (charge/discharge operation). These differences could cause electrolyte leakage or heat generation.

CAUTION

- (1) To prevent accidents from happening, change any battery that is found to have an abnormality such as a crack, a deformity, or leakage. The batteries must be kept clean and free from dust to prevent loss of capacity or accident.
- (2) If any abnormality of the charge voltage or the discharge voltage is detected replace the batteries with new ones.
- (6) Do not remove or scratch the outer tube of the battery or it may cause an electrolyte leakage or electrical leakage.
- (7) Do not allow the batteries to be subjected to any strong physical shocks or jolts while moving them. Treating the batteries roughly could cause leaks, heat generation, or a explosions.
- (8) Do not charge the batteries beyond the amount of the time indicated in the specifications, or do not charge after the charge indication lamp indicates a full charge. Take the batteries off the charger if the charge is not finished after the specified charge time. Over-charging can cause leakage, heat generation, or explosions.
- (9) Children should be taught how to handle and use the batteries correctly.
- (10) Keep the batteries out of the reach of small children at all times.

REQUEST

- (1) The cut-off voltage during discharge should vary depending on the discharge current. Do not discharge the batteries lower than the recommended cut-off voltage shown in Panasonic specifications or Panasonic technical handbooks. Recharging a battery which was once discharged below the recommended cut-off voltage may generate heat, resulting in the deformation of the battery or in condensation around the battery cover caused when moisture within the battery evaporates. In addition, the efficiency of the battery would eventually decrease. Overdischarging a battery may result in reduced performance. Always recharge the batteries immediately after discharge even if the batteries were not discharged to the recommended cut-off voltage. If the batteries are not charged soon after discharge, the batteries performance may be reduced due to the so-called "sulfation phenomena".

Note: The cut-off device to prevent overdischarge should cut off all discharge current including any weak current.
- (2) Thoroughly study the charge methods and the conditions of the batteries before adopting other charge methods which are not shown in the Panasonic specifications or the Panasonic technical handbook, for safety reasons.
- (3) When the batteries are used in a cyclic application, it is important to charge the batteries for the proper amount of time. A timer should be incorporated into the charging circuit that will disconnect the charging current to prevent overcharging. Also, it is important to allow the battery to completely charge before removing the battery from the charger.
- (4) Avoid parallel charging of the batteries in cycle use. This may shorten the life of the batteries by causing an imbalance in the charge/discharge operation of the batteries.
- (5) Measure the total voltage of the batteries during trickle charge (or float charge), using a voltage meter. If the total voltage of the batteries provide an indication deviating from the specified voltage range, be sure to investigate the cause. If the total voltage is lower than that specified, the batteries may lose their capacity because of a lack of sufficient charge. However, if the total voltage is higher than that specified, the batteries may lose their capacity by damage due to overcharge and may suffer from "thermal runaway" and other accidents.
- (6) Switch off the equipment after use to prevent loss of performance or shortened life of the batteries due to damage overdischarge.
- (7) When storing the batteries, be sure to remove them from the equipment or disconnect them from the charger and the load to prevent overdischarge and loss of capacity. Before storing batteries, charge the batteries fully. Do not store batteries in a highly humid place to prevent rust from forming on the terminals.

PRECAUTIONS FOR HANDLING VRLA-BATTERIES-CONTINUED

6. Maintenance

WARNING

- (1) When cleaning the batteries, use a soft damp cloth. A dry cloth may cause static electricity which could result in a fire or explosion.
- (2) Replace batteries with the new ones before the end of their useful life as determined in the specifications. When the batteries near the end of their life (50% state of their initial discharge duration time) will shorten remarkably. Finally the batteries will lose their available capacity by either drying out their electrolyte (causing increase in their internal resistance) or an internal short-circuit. In such case, if the batteries go on charging, thermal runaway and/or leakage of electrolyte may occur. The batteries should be replaced before becoming in these state.

The expected life of the batteries (in trickle or float use) will decrease to half (50%) with each 10°C rise in temperature above 20°C. In particular, the life of the batteries will be shortened remarkably at approximately 40°C. Accordingly, precautions are required to prevent the use of batteries at high temperatures.

CAUTION

- (1) Avoid using organic solvents such as thinner, gasoline, lamp oil or benzine and liquid detergent to clean the batteries. These substances may cause the battery containers to crack or leak.

REQUEST

- (1) Keep the battery terminals clean in order to avoid interruption in the discharge and/or to maintain the charge.

7. Treatment at Emergency

WARNING

- (1) The batteries have toxic liquid - dilute sulfuric acid solution in them. If the acid comes into contact with skin or clothes, wash skin or cloth with lots of clean water to prevent scalding from occurring. If the acid should come into contact with the eyes, wash the eyes with lots of clean water and consult a physician immediately to prevent possible loss of sight.

CAUTION

- (1) Check the batteries visually for any sign of irregularities in appearance. If any damage exists such as cracks, deformation, leakage of electrolyte, or corrosion, the batteries must be replaced with the new ones. Irregularities in the batteries could result in bodily injury, electrolyte leakage, excessive heat generation or explosion, if used. Furthermore, make sure the batteries are clean and free from dirt and dust.

PRECAUTIONS FOR HANDLING VRLA-BATTERIES-CONTINUED

8. Storage

CAUTION

- (1) Store the batteries in a fixed position separate from metal or other conductive materials.
- (2) Keep the batteries from rain water that could cause corrosion on the terminals of the batteries.
- (3) Keep the batteries right-side-up during transportation and do not give any abnormally strong shock and jolt to the batteries. Transporting the batteries in an abnormal position or handling them roughly could destroy the batteries or cause their characteristics to deteriorate.
- (4) When storing the batteries, be sure to remove them from the equipment or disconnect them from the charger and the load, then store them at room temperature or lower temperature. Do not store the batteries at direct sunlight, higher temperature or high humidity. To do so cause the batteries short life, performance deterioration or corrosion on terminals.

REQUEST

- (1) Charge the batteries at least once every six months if they are stored at 20°C. Use the charge method specified in "3. Preparation Prior to Use". The interval of this charge should be reduced to 50% by each 10°C rise in temperature above 20°C.
The self-discharge rate doubles for each 10°C in temperature. If they are stored for a long time in a discharged state, their capacity may not recover even after charge. If the batteries are stored for more than a year at room temperature, the life of the batteries may be shortened.
- (2) Store the batteries starting from the fully charged state to prevent the life of the batteries being shortened.
- (3) Use the batteries as quickly as possible after receiving them as they gradually deteriorate even under proper storage conditions.

9. Disposal and Recycling

CAUTION

- (1) Please write the information about battery recycling on the equipment, the package, the carton, the instruction manual etc. in countries where legal or voluntary regulations on battery recycling are applicable.
- (2) Design the equipment such that exchange and disposal of the batteries can be undertaken easily.
- (3) Used batteries should be recycled. When returning used batteries, insulate their terminals using adhesive tape, etc. Even used batteries still have electrical charge and an explosion or a fire may occur, if proper insulation is not given on the terminals of the used batteries.

OVERVIEW



Overview

Panasonic valve regulated lead-acid battery (VRLA battery) have been on the market for more than 30 years. The VRLA battery is a rechargeable battery which requires no watering. Adopting lead-tin-calcium alloy as the grid alloy, it has outstanding characteristics against severe use conditions such as overcharge, overdischarge, vibration, shock and also for various storage condi-

tions. Our accumulation of technologies has enabled us to respond to market requirements promptly by developing batteries such as trickle and cycle long life type.

The VRLA battery covers a broad range of applications including, electric tools, UPS, and three and four wheel electric wheel chairs for the elderly.

Battery Types and model numbers

For main power source — Cycle long life typeLC-XC

For main and standby power source — Trickle Design life 6*) years.....LC-R,L

For standby power source — Trickle Design life 6*) years.....UP-RW
 — Trickle Design life 10*) years — Standard caseLC-X
 — Flame-retardant case ..LC-P

Trickle Design life:
 Temperature: 20°C
 Discharge current: 0.1CA
 Discharge ending voltage: 5.4V for 6V battery, 10.8V for 12V battery
 Charge voltage: 6.85V for 6V battery, 13.7V for 12V battery
 *) Trickle Design life conform to Eurobat

* For more details regarding MSE batteries, please refer to the separate technical handbook of "MSE Batteries." For more details regarding Super MSE batteries, please see "Super MSE Batteries" page in our "Short Form Catalog."

GENERAL INFORMATION ON VRLA-BATTERIES

Construction and Electrolyte

- **Positive plates**

Positive plates are plate electrodes of which a grid frame of lead-tin-calcium alloy holds porous lead dioxide as the active material.

- **Negative plates**

Negative plates are plate electrodes of which a grid frame of lead-tin-calcium alloy holds spongy lead as the active material.

- **Electrolyte**

Diluted sulfuric acid is used as the medium for conducting ions in the electrochemical reaction in the battery.

- **Separators**

Separators, which retain electrolyte and prevent shorting between positive and negative plates, adopt a non-woven fabric of fine glass fibers which is chemically stable in the diluted sulfuric acid electrolyte. Being highly porous, separators retain electrolyte for the reaction of active materials in the plates.

- **Vent (One way valve)**

The vent is comprised of a one-way valve made of material such as neoprene. When gas is generated in the battery under extreme overcharge condition due to erroneous charging, charger malfunctions or other abnormalities, the valve opens to release excessive pressure in the battery and maintain the gas pressure within specific range (0.07 – 0.44 bar).

During ordinary use of the battery, the valve is closed to shut out outside air and prevent oxygen in the air from reacting with the active material in the negative electrodes.

- **Positive and negative electrode terminals**

Positive and negative electrode terminals may be faston tab type, bolt fastening type, threaded post type, or lead wire type, depending on the type of the battery. Sealing of the terminal is achieved by a structure which secures long adhesive-embedded paths and by the adoption of strong epoxy adhesives. For specific dimensions and shapes of terminals, see page 67.

- **Battery case materials**

Materials of the body and cover of the battery case are ABS resins, unless otherwise specified.

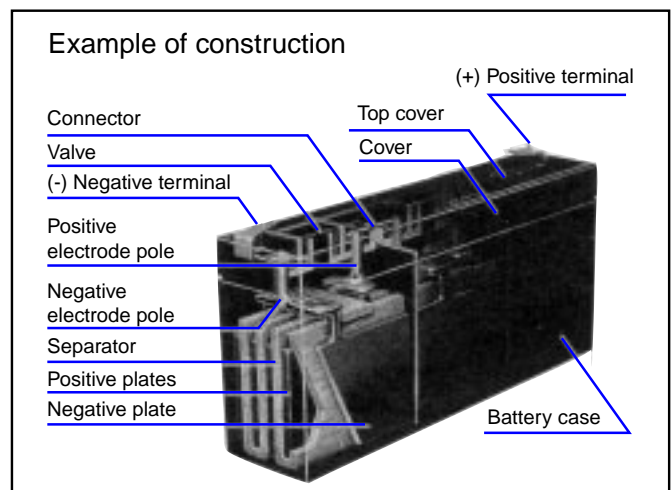

Electrochemical Reactions on Electrodes

The electrochemical reaction processes of the sealed lead-acid battery (negative electrode recombination type) are described below. Where “charge” is the operation of supplying the rechargeable battery with direct current from an external power source to change the active material

in the negative plates chemically, and hence to store in the battery electric energy in the form of chemical energy. “Discharge” is the operation of drawing out electric energy from the battery to operate external equipment.

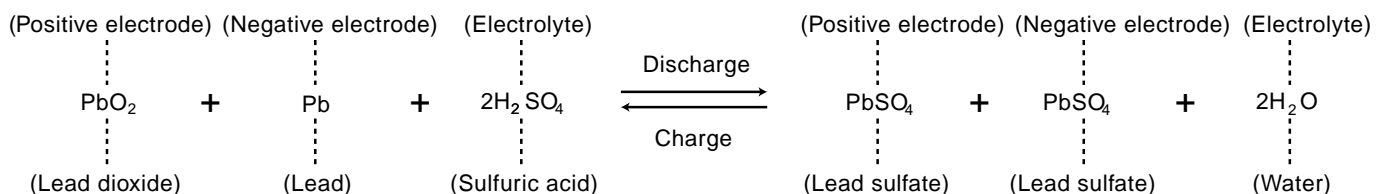

GENERAL INFORMATION ON VRLA-BATTERIES - CONTINUED

In the final stage of charging, an oxygen-generating reaction occurs at the positive plates. This oxygen transfers inside the battery, then is absorbed into the

surface of the negative plates and consumed. These electrochemical reaction processes are expressed as follows.

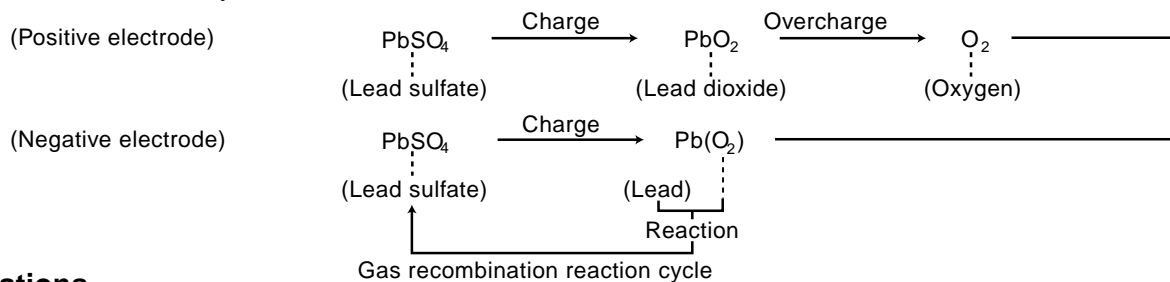

Applications

- **Stand-by/Back-up power applications**

- Communication equipment: base station, PBX, CATV, WLL, ONU, STB, etc.
- Back-up for power failure: UPS, ECR, computer system back-up, sequencers, etc.
- Emergency equipment: lights, fire and burglar alarms, radios, fire shutters, stop-position controls (for machines and elevators), etc.

- **Main power applications**

- Electrically operated vehicles: picking carts, automated transports, electric wheelchairs, cleaning robots, electric automobiles, electric lawnmowers, etc.

- Tools and engine starters: grass shears, hedge trimmers, scouters, jet-skis, electric saws, etc.
- Industrial equipment/instruments and non life-critical medical equipment*: measuring equipment, non life-critical medical equipment (electrocardio-graph), etc.
- Photography: camera strobes, VTR/VCR, movie lights, etc.
- Toys and hobby: radio-controllers, motor drives, lights, etc.
- Miscellaneous uses: integrated VTR/VCR, tape recorders, other portable equipment, etc.

*(Note) When any medical equipment incorporating a Panasonic VRLA battery is planned, please contact Panasonic.

Features

- **Leak-resistant structure**

A required-minimum quantity of electrolyte is impregnated into, and retained by, the positive and negative plates and the separators; therefore electrolyte does not flow freely. Also, the terminal has a sealed structure secured by long adhesive-embedded paths and by the adoption of strong epoxy adhesives which makes the battery leak-resistant. (Note) In stand-by/back-up uses, if the battery continues to be used beyond the point where discharge duration has decreased to 50% of the initial (i.e. life judgment criteria), cracking of the battery case may occur, resulting in leakage of the electrolyte.

- **Long service life**

Service life of our long-life series (LC-P, LC-X series) is approximately double that of the conventional (LC-R and LC-L series) batteries (Temperature 20°C), discharge rate 0.25 CA/ 1.75V/cell, discharge frequency every 6 months, 2.30V/cell charge).

- **Easy maintenance**

Unlike the conventional batteries in which electrolyte can flow freely, VRLA batteries do not need the specific-gravity check of the electrolyte nor the watering structurally; this makes the battery function fully and makes maintenance easy.

- **No sulfuric acid mist or gases**

Unlike the conventional batteries in which electrolyte can flow freely, VRLA batteries generate no sulfuric acid mist or gases under the use condition we recommend. In uses under conditions other than recommended, however, gas generation may occur, therefore do not design the battery housing with a closed structure.

- **Exceptional deep discharge recovery**

As seen in the figure on the next page, our VRLA battery shows exceptional rechargeability even after deep discharge, which is often caused by failure to turn off the equipment switch, followed by standing (approx. 1 month at room temperature is assumed).

GENERAL INFORMATION ON VRLA-BATTERIES - CONTINUED

Transportation

Our VRLA batteries should be handled as common cargo for both air shipment (*1) and boat shipment (*2), as they can withstand electrolyte leakage during the vibration test, the differential atmospheric pressure test and the altitude test in accordance with the special requirements of transportation regulations specified by the international organizations (ICAO: International Commercial Aviation Organization and IMO: International Maritime Organization).

(*1: Special provision A67 *2: Special provision 238)

- **ISO9001**

After an evaluation by the JQA (Japan Quality Association), under their Quality Assurance Corporate Registration System, the quality system at our Hamanako plant, which is where we manufacture our valve regulated lead-acid batteries, was recognized and registered as conforming with ISO 9001-1994/BS EN ISO 9001:1994/EN-ISO 9001-1994/JIS Z9901-1994. (Registered certification number: JQA-1113 Date issued: December 28, 1995)

- **ISO 14001**

After an assessment by the JACO (Japan Audit and Certification Organization for Environment), the Environmental Management System at our HAMANAKO site was approved with the standard ISO 14001:1996 JIS Q 14001:1996. (Approval Certificate number: EC97J1085 Issue Date: 30/09/1997)

- **JIS (Japan Industrial Standards)**

Our sealed lead-acid batteries comply with JIS C 8702, and our MSE cathode absorption-type sealed

Example of rechargability after deep discharge and standing

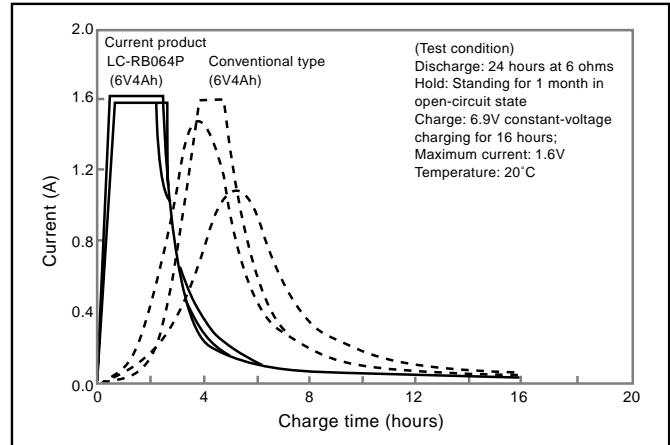

batteries comply with JIS C 8707. (Some of the small-sized sealed lead-acid batteries conform with JIS.)

- **UL recognition**

Our VRLA batteries fall into UL1989 (Standby Batteries). UL1989 requires that the battery is free from the hazard of bursting, that is, when the battery is over-charged the vent valve opens to release internal pressure. UL-recognized types of VRLA batteries to date are listed in the following table. A number of the recognized battery types are in use for such applications as emergency lights.

- **VdS and other recognition**

The types of VRLA batteries which have acquired VdS (Germany) recognition and the Japanese recognition to date are also listed.

Table of battery types which acquired local/overseas recognition

| Standard/recognition | Contents | Recognition number | Recognized Models |
|----------------------------|------------------------------|---|---|
| UL U.S. Safety standard | UL 1989 Standby Batteries | MH13723 | LC-R063R4(a) LC-R064R2(a) LC-R067(a) LC-R067R2(a) LC-R0611(a) LC-R0612(a) LC-R122R2(a) LC-R123R4(a) LC-R127(a) LC-R127R2(a) LC-RD1217(a) LC-RA1212(a) LC-LA1233(a) LC-V067R2(a) LC-V0612(a) LC-V121R3(a) LC-V122R2(a) LC-V123R4(a) LC-V127R2(a) LC-VA1233(a) LC-P067R2(a) LC-P0612(a) LC-VD1217(a) LC-P127R2(a) LC-X1220(a) LC-X1224(a) LC-X1228(a) LC-X1238(a) LC-X1242(a) LC-X1265(a) LC-XB12100(a) LC-N02500(a) UP-RW1245(a) MSE-50-12(a) MSE-100-6(a) MSE-150(a) MSE-200(a) MSE-300(a) MSE-500(a) MSE-1000(a) MSE-1500(a) MSE-2000(a) MSE-3000(a) |
| VdS German Safety Standard | | G196049 G188151 G191053 G198048 G193046 G100001 G198049 G100002 G199090 | LC-R121R3PG LC-R127P/P1 LC-X1224APG/AP LC-R122R2PG LC-R127R2PG/P1 LC-X1238APG/AP LC-X1238PG/P LC-R123R4PG LC-RA1212PG/P1 LC-RA1212P/P1 LC-X1265PG/P |

Additional configuration codes (alphabetic letters or numbers) may appear for (a) in the code numbers of UL recognized types.

(Note) These standards are also valid for old model numbers.

ISO - The Quality System and the Environmental Management System at our plants were recognized and registered as conforming to ISO

| | ISO 9001 | ISO 9002 | ISO 14001 |
|------------------|----------|----------|-----------|
| MBI-SBD (Japan) | O | | O |
| SLMB (China) | | O | O |
| MBIA-MX (Mexico) | | O | O |

CHARACTERISTICS

• Charging

Charge characteristics (constant voltage-constant current charging) of VRLA batteries are exemplified below.

Example of constant-voltage charge characteristics by current

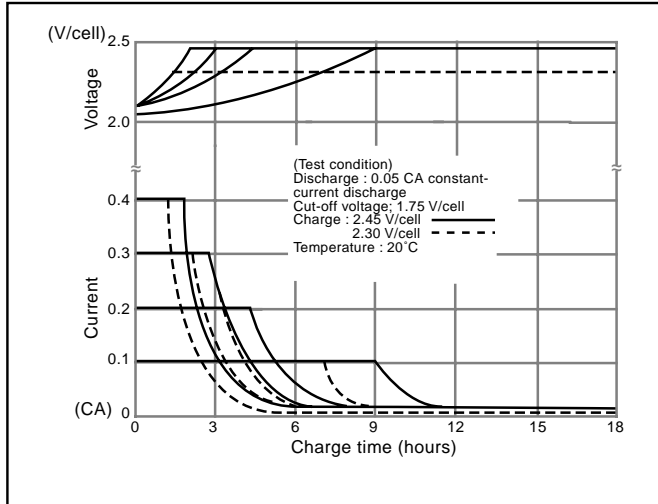

In order to fully utilize the characteristics of VRLA batteries, constant-voltage charging is recommended. For details of charging see page 19.

• Discharging

a) Discharge current and discharge cut-off voltage

Recommended cut-off voltages for 6V and 12V batteries consistent with discharge rates are given in the figure below. With smaller discharge currents, the active materials in the battery work effectively, therefore discharge cut-off voltages are set to the higher side for controlling overdischarge. For larger discharge currents, on the contrary, cut-off voltages are set to the lower side.

(Note) Discharge cut-off voltages given are recommended values.

Discharge current vs. Cut-off voltage

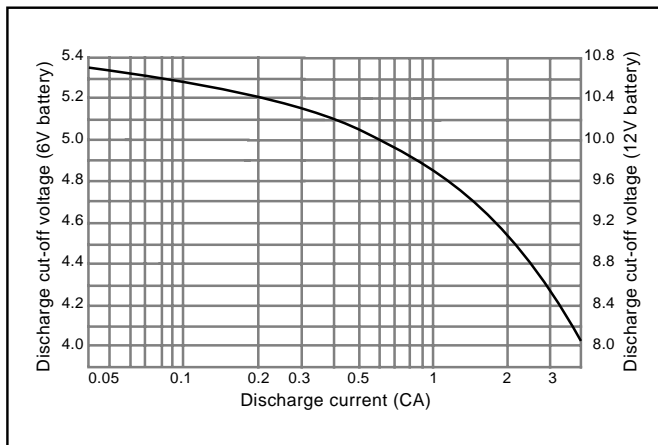

b) Discharge temperature

(1) Control the ambient temperature during discharge within the range from -15°C to 50°C for the reason described below.

(2) Batteries operate on electrochemical reaction which converts chemical energy to electric energy. The electrochemical reaction is reduced as the temperature lowers, thus, available discharge capacity is greatly reduced at temperatures as low as -15°C. For the high temperature side, on the other hand, the discharge temperature should not exceed 50°C in order to prevent deformation of resin materials which house the battery or deterioration of service life.

c) Effect of temperature on discharge characteristics

Available discharge capacity of the battery varies with ambient temperature and discharge current as shown in the figure below.

Discharge capacity by temperature and by discharge current

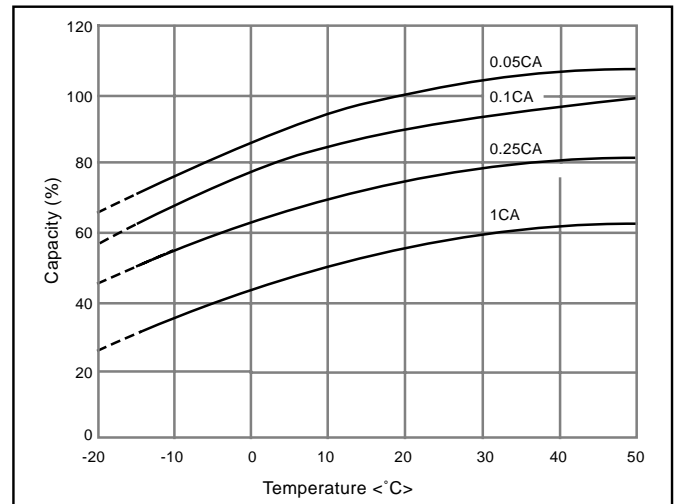

CHARACTERISTICS - CONTINUED

d) Discharge current

Discharge capability of batteries is expressed by the 20 hour rate (rated capacity). Select the battery for specific equipment so that the discharge current during use of the equipment falls within the range between 1/20 of the 20 hour rate value and 3 times that (1/20 CA to 3 CA): discharging beyond this range may result in a marked decrease of discharge capacity or reduction in the number of times of repeatable discharge. When discharging the battery beyond said range, please consult Panasonic in advance.

(Note) With some types of VRLA batteries which have a built-in thermostat, the thermostat may automatically cut off the circuit when discharge current exceeds 4 A at the ambient temperature of 40°C; therefore, the maximum discharge current value should be the smaller one of either 4 A or 2 CA.

e) Depth of discharge

Depth of discharge is the state of discharge of batteries expressed by the ratio of amount of capacity discharged to the rated capacity.

• Storage

a) Storage condition

Observe the following condition when the battery needs to be stored.

- (1) Ambient temperature: -15°C to 40°C (preferably below 30°C)
- (2) Relative humidity: 25 to 85%
- (3) Storage place free from vibration, dust, direct sunlight, and moisture.

b) Self discharge and refresh charge

During storage, batteries gradually lose their capacity due to self discharge, therefore the capacity after storage is lower than the initial capacity. For the recovery of capacity, repeat charge/discharge several times for the battery in cycle use; for the battery in trickle use, continue charging the battery as loaded in the equipment for 48 to 72 hours.

c) Refresh charge (Auxiliary charge)

When it is unavoidable to store the battery for 3 months or longer, periodically recharge the battery at the intervals recommended in the table below depending on ambient temperature. Avoid storing the battery for more than 12 months.

| Storage temperature | Interval of auxiliary charge (refresh charge) |
|---------------------|---|
| Below 20°C | 12 month |
| 20°C to 30°C | 9 month |
| 20°C to 40°C | 6 month |

d) Residual capacity after storage

The result of testing the residual capacity of the battery which, after fully charged, has been left standing in the open-circuit state for a specific period at a specific ambient temperature is shown in the figure below. The self discharge rate is very much dependent on the ambient temperature of storage. The higher the ambient temperature, the less the residual capacity after storage for a specific period. Self discharge rate almost doubles by each 10°C rise of storage temperature.

Residual capacity test result

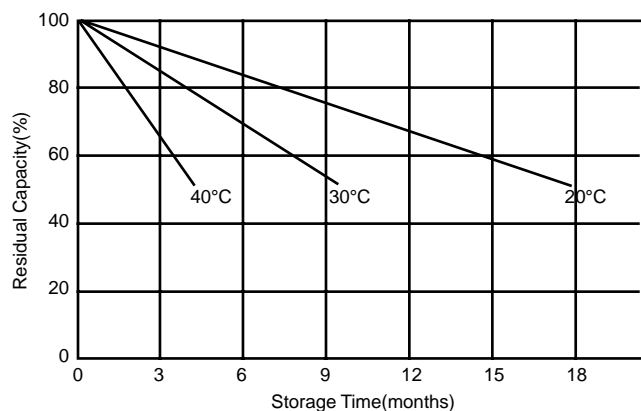

CHARACTERISTICS - CONTINUED

e) Open circuit voltage vs. residual capacity

Residual capacity of the battery can be roughly estimated by measuring the open circuit voltage as shown in the Figure.

Open circuit voltage vs. Residual capacity 20°C

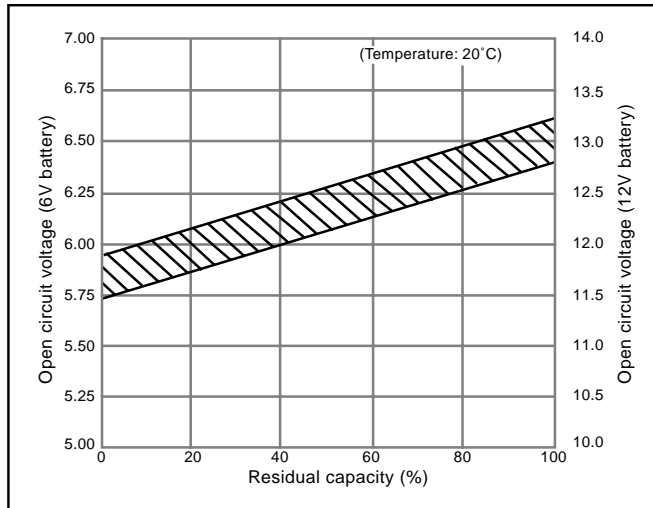

• Temperature conditions

Recommended temperature ranges for charging, discharging and storing the battery are tabulated below.

| | |
|------------------|---------------|
| Charge | 0°C ~ 40°C |
| Discharge | -15 °C ~ 50°C |
| Storage | -15 °C ~ 40°C |

• Battery life

a) Cycle life

Cycle life (number of cycles) of the battery is dependent on the depth of discharge in each cycle. The deeper the discharge is, the shorter the cycle life (smaller number of cycles), providing the same discharge current. The cycle life (number of cycles) of the battery is also related to such factors as the type of the battery, charge method, ambient temperature, and rest period between charge and discharge. Typical cycle-life characteristics of the battery by different charge/discharge conditions are shown by the below figures.

This data is typical and tested at a well-equipped laboratory.

Cycle times are different for each battery model.

Cycle times are also different from this data when using batteries under real conditions.

Cycle life vs. Depth of discharge

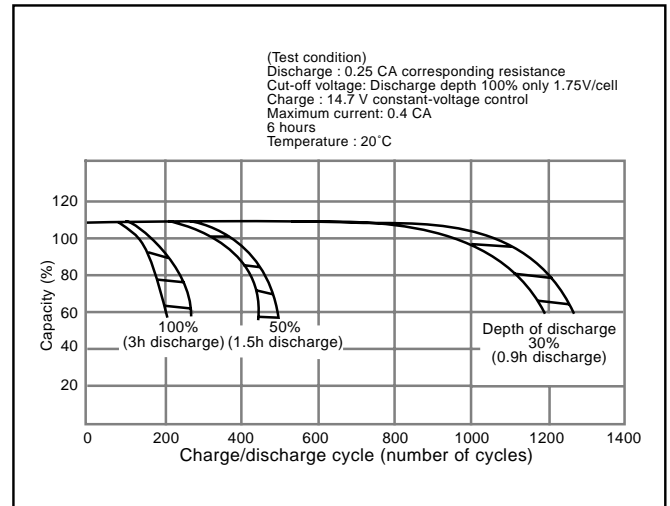

CHARACTERISTICS - CONTINUED

b) Trickle (Float) life

Trickle life of the battery is largely dependent on the temperature condition of the equipment in which the battery is used, and also related to the type of the battery, charge voltage and discharge current. The respective Figures show the influence of temperature on trickle life of the battery, an example of trickle (float) life characteristics of the battery, and the test result of the battery life in an emergency lamp.

Influence of Temperature on Trickle life

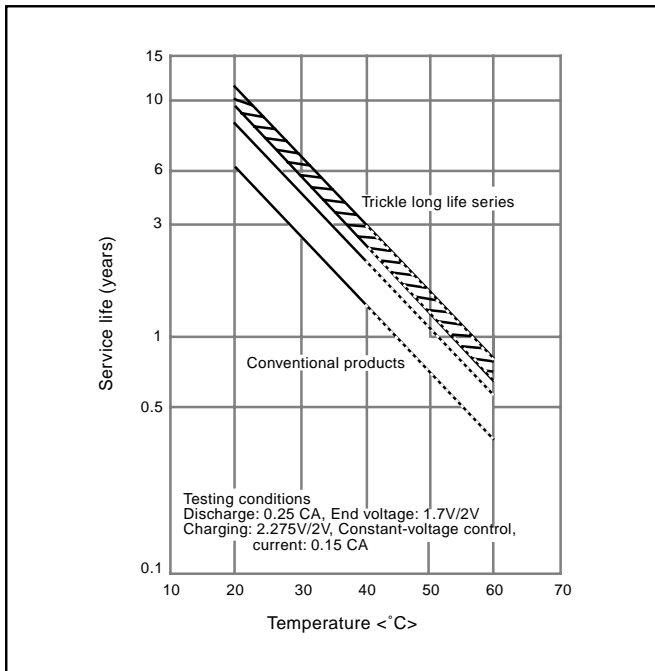

Trickle life characteristics at 50°C

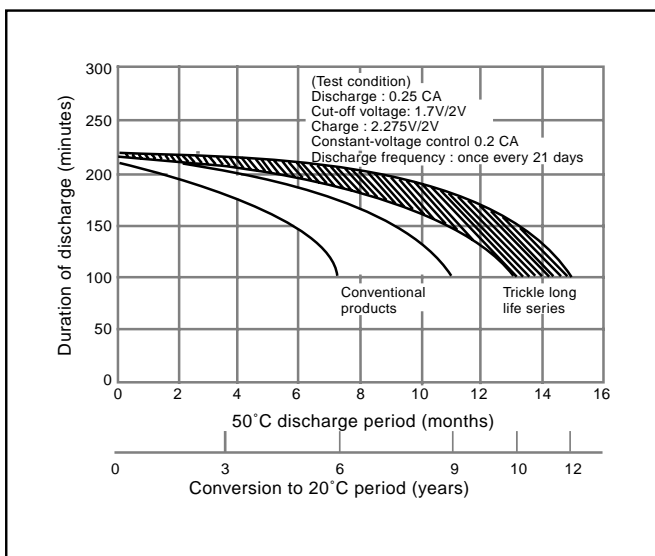

CHARGING METHODS

Methods of Charging the Valve Regulated Lead-Acid Battery

For charging the valve regulated lead-acid battery, a wellmatched charger should be used because the capacity or life of the battery is influenced by ambient temperature, charge voltage and other parameters.

Charging methods are dependent on battery applications, and the applications are roughly classified into main power application and stand-by/back-up power applications.

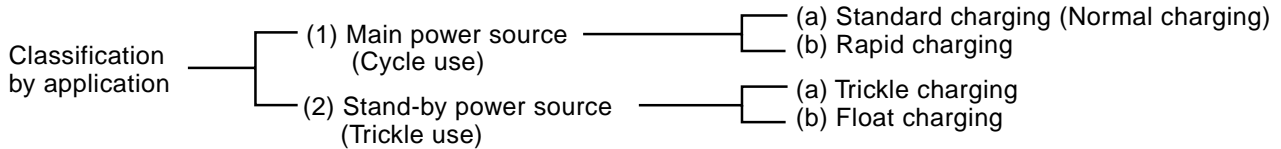

(1) Main Power cycle use

Cycle use is to use the battery by repeated charging and discharging in turn.

(a) Standard charging (Normal charging)

For common applications of the battery, the constant voltage charge method is advantageous as it allows the battery to exert full performance.

- **Constant voltage charging method**

This method is to charge the battery by applying a constant voltage between the terminals. When the battery is charged by applying a voltage of 2.45 V per cell (unit battery) at a room temperature of 20°C to 25°C, charging is complete when the charge current continues to be stable for three hours. Valve regulated lead-acid batteries can be overcharged without constant voltage control. When the battery is overcharged, the water in the electrolyte is decomposed by electrolysis to generate more oxygen gas than what can be absorbed by the negative electrode. The electrolyte is changed to oxygen gas and hydrogen gas, and lost from the battery system. As the quantity of electrolyte is reduced, the chemical reactions of charge and discharge become inefficient and hence the battery performance is severely deteriorated. Therefore, exact voltage control and proper charging time in constant voltage charging are essential for securing the expected life of the battery.

- **Constant-voltage and constant-current charging method**

This method is to charge the battery by controlling the current at 0.4 CA and controlling the voltage at 2.45 V / per cell (unit battery) at a room temperature of 20°C to 25°C. Proper charging time is 6 to 12 hours depending on discharge rate.

Constant-voltage constant-current charge characteristics

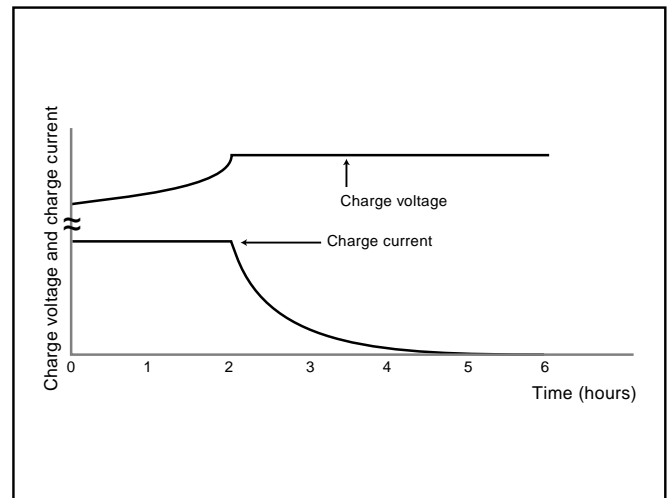

CHARGING METHODS - CONTINUED

(b) Rapid charging

When rapidly charging the battery, a large charge current is required in a short time for replenishing the energy which has been discharged. Therefore, some adequate measures such as the Control of charge current is required to prevent overcharging when the rapid charging is complete. Basic requirements for rapid charging are as follows:

- Sufficient charging should be made in a short time for fully replenishing the amount discharged.
- Charge current should be automatically controlled to avoid overcharge even on prolonged charging.
- The battery should be charged adequately in the ambient temperature range of 0°C to 40°C.
- Reasonable cycle life of charge/discharge should be secured.

Typical methods to control charging so as to satisfy the above requirements follow.

- **Two-step constant voltage charge control method**

Two-step constant voltage charge control method uses two constant-voltage devices. At the initial stage, the battery is charged by the first constant-voltage device SW(1) of high setup voltage (set-up for cycle charge voltage). When the charge current, the value of which is detected by the current-detection circuit, has reduced to the preset value, the device is switched over to the second SW(2) of low set-up voltage (setup for trickle charge voltage). This method has the advantage that the battery in trickle use can be charged in a comparatively short time for the next discharge.

Charging characteristics of the two-step constant voltage charger

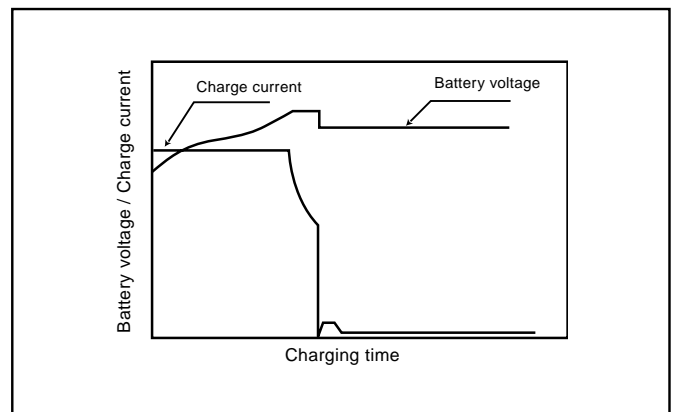

Block diagram of the two-step constant voltage control charger

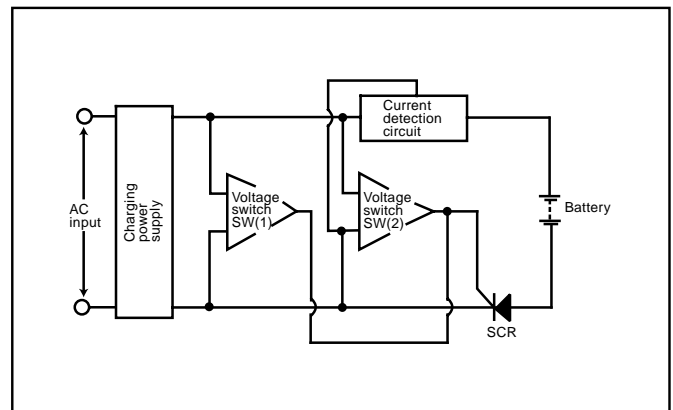

CHARGING METHODS - CONTINUED

(1) Stand-by/Back-up use (Trickle use)

The application load is supplied with power from AC sources in normal state. Stand-by/back-up use is to maintain the battery system at all times so that it can supply power to the load in case the AC input is disrupted (such as a power failure). There are two methods of charging for this use.

(a) Trickle charge (Compensating charge)

• Trickle charge

In this charge system, the battery is disconnected from the load and kept charged with a small current only for compensating self discharge while AC power is alive. In case of power failure, the battery is automatically connected to the load and battery power is supplied. This system is applied mainly as a spare power source for emergency equipment. In this use, if rapid recovery of the battery after discharge is required, it is necessary to consider the recovery charge with a comparatively large current followed by trickle charge, or alternative measures.

While the type and capacity of the battery is determined by the back-up time and the load (current consumption) during power failure, some reserve power should be taken into account considering such factors as ambient temperature, capability of the charger and depth of discharge.

Trickle charge system model

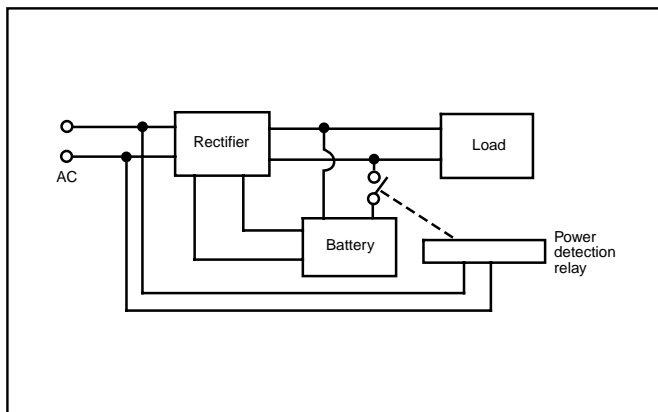

(Precautions on charging)

1. As the battery continues to be charged over a long period, a small difference in charging voltage may result in a significant difference in the battery life. Therefore, charge voltage should be controlled within a narrow range and with little variation for a long period.
2. As charge characteristics of the battery are dependent on temperature, compensation for temperature variation is required when the battery is used over a broad temperature range, and the system should be designed so that the battery and the charger are kept at the same temperature.

• Float charge

Float system is the system in which the battery and the load are connected in parallel to the rectifier, which should supply a constant-voltage current.

Float charge system model

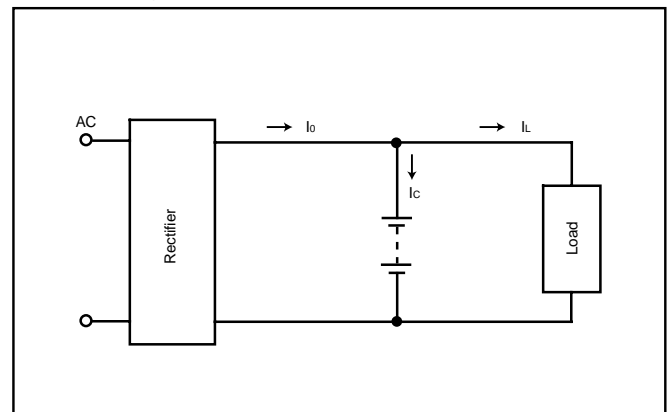

In the above-illustrated model, output current of the rectifier is expressed as:

$I_o = I_c + I_L$ where I_c is charge current and I_L is load current. Consideration should be given to secure adequate charging because, in fact, load current is not constant but irregular in most cases.

In the float system, capacity of the constant-voltage power source should be more than sufficient against the load. Usually, the rectifier capacity is set at the sum of the normal load current plus the current needed in order to charge the battery.

CHARGING METHODS - CONTINUED

Charging Methods and Applications of VRLA-Batteries

| Application/ Charging Method | Normal charging in 6 or more hours; Constant voltage control | Two-step constant voltage control | Constant current control |
|------------------------------------|--|---|---|
| Cycle use | Control voltage : 7.25 to 7.45V /6V battery 14.5 to 14.9V /12V battery Initial current : 0.4 CA or smaller | | |
| Trickle use | Control voltage : 6.8 to 6.9V /6V battery 13.6 to 13.8V /12V battery | Initial charging with current of approx. 0.15 CA, followed by switching voltage to trickle charge | |
| Float use | Control voltage : 6.8 to 6.9V /6V battery 13.6 to 13.8V /12V battery Float charging compensates for load fluctuations. | | |
| Refresh charge (Auxiliary charge)* | When charging two or more batteries at a time, select only those which have been left under the same condition. | | Charging with current of approx. 0.1 CA |
| Application example | General uses, Cellular phones (bag phones), UPS, Lanterns, Electric tools | Medical equipment, Personal radios | |

Note * Refresh (auxiliary) charge amount should be 120 to 130 % of self-discharge amount. For details, please contact us.

(Precautions on charging)

- (a) in constant voltage charging (cycle use): Initial current should be 0.4 CA or smaller (C: rated capacity)
(b) in V-taper charge control system: Initial current should be 0.8 CA or smaller (C: rated capacity)
(c) in constant voltage charging (trickle use): Initial current should be 0.15 CA or smaller (C: rated capacity)
- Relation between standard voltage value in constant voltage charging and temperature is given in the Table.

Relation between standard voltage value in constant voltage charging and temperature

| | | 0°C | 20°C | 40°C |
|-------------|-----|------|------|------|
| Cycle use | 6V | 7.7 | 7.4 | 7.1 |
| | 12V | 15.4 | 14.7 | 14.2 |
| Trickle use | 6V | 7.1 | 6.8 | 6.7 |
| | 12V | 14.1 | 13.7 | 13.4 |

CHARGING METHODS - CONTINUED

a) Temperature compensation of charge voltage

Charge voltage should be compensated to the ambient temperature near the battery, as shown by the figure below. Main reasons for the temperature compensation of charge voltage are to prevent the thermal runaway of the battery when it is used in high temperature conditions and to secure sufficient charging of the battery when it is used in low temperature conditions. Prolongation of service life of the battery by the above-described temperature compensation is expected as follows

- At 30°C: prolonged by approx. 5 %
- At 35°C: prolonged by approx. 10 %
- At 40°C: prolonged by approx. 15 %

In low temperature zones below 20°C, no substantial prolongation of the battery life can be expected by the temperature compensation of charge voltage.

Compensated voltage value

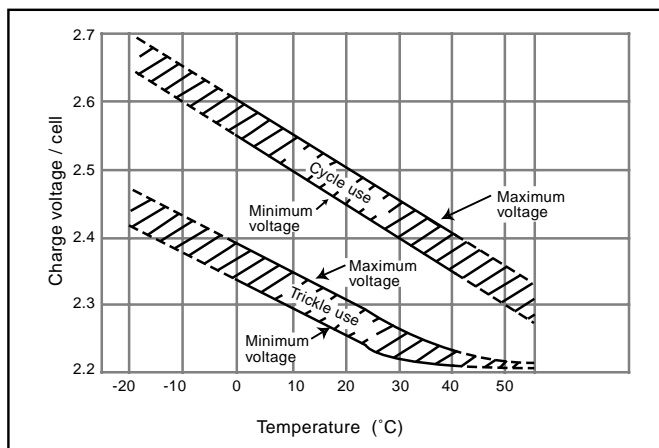

b) Charging time

Time required to complete charging depends on factors such as depth of discharge of the battery, characteristics of the charger and ambient temperature. For cycle charge, charging time can be estimated as follows:

(1) when charge current is 0.25 CA or greater:

$$T_{ch} = C_{dis} / I + (3 \text{ to } 5)$$

(2) when charge current is below 0.25 CA:

$$T_{ch} = C_{dis} / I + (6 \text{ to } 10), \text{ where}$$

T_{ch} : Charging time required (hours)

C_{dis} : Amount of discharge before this charging (Ah)

I : Initial charge current (A)

Time required for trickle charge ranges from 24 to 48 hours.

c) Charging temperature

- (1) Charge the battery at an ambient temperature in the range from 0°C to 40°C.
- (2) Optimum temperature range for charging is 5°C to 35°C.
- (3) Charging at 0°C or below and 40°C or higher is not recommended: at low temperatures, the battery may not be charged adequately; at high temperatures, the battery may become deformed.
- (4) For temperature compensation values, see a).

d) Reverse charging

Never charge the battery in reverse, as it may cause leakage, heating or bursting of the battery.

e) Overcharging

Overcharge is an additional charge after the battery is fully charged. Continued overcharging shortens the battery life. Select a charge method which is specified or approved for each application.

f) Charging before use

Recharge the battery before use to compensate for capacity loss due to self-discharge during storage. (See "Refresh charge" (auxiliary charge) table on page 18.)

CHARGING METHODS - CONTINUED

- Characteristics of constant voltage chargers**

Even with the same voltage set-up, charging time varies with output V-I characteristics.

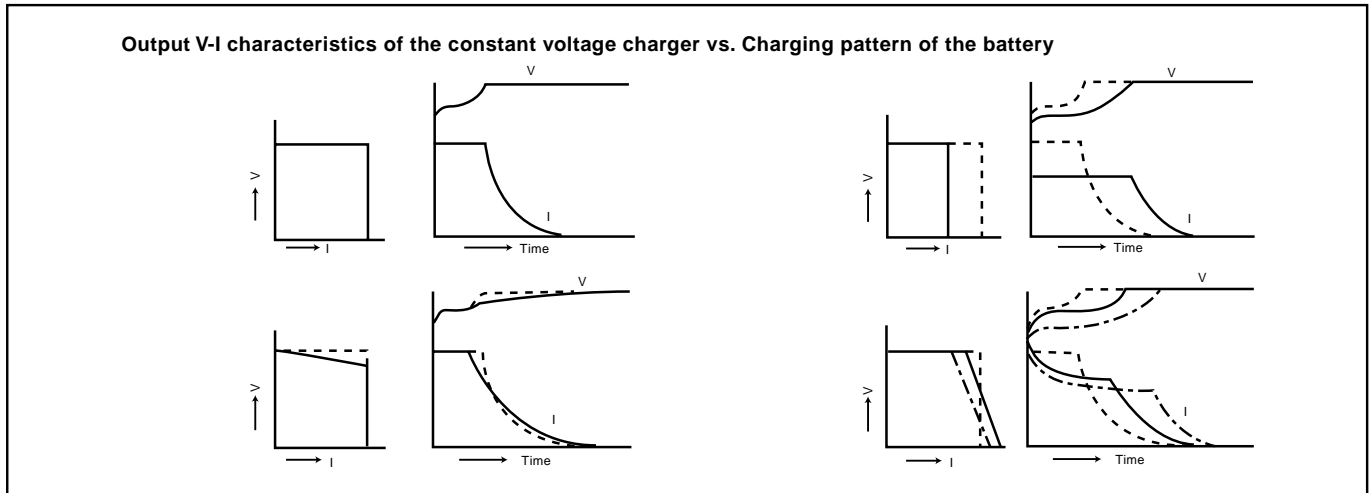

- Constant voltage charger circuitry (Concept diagram)**

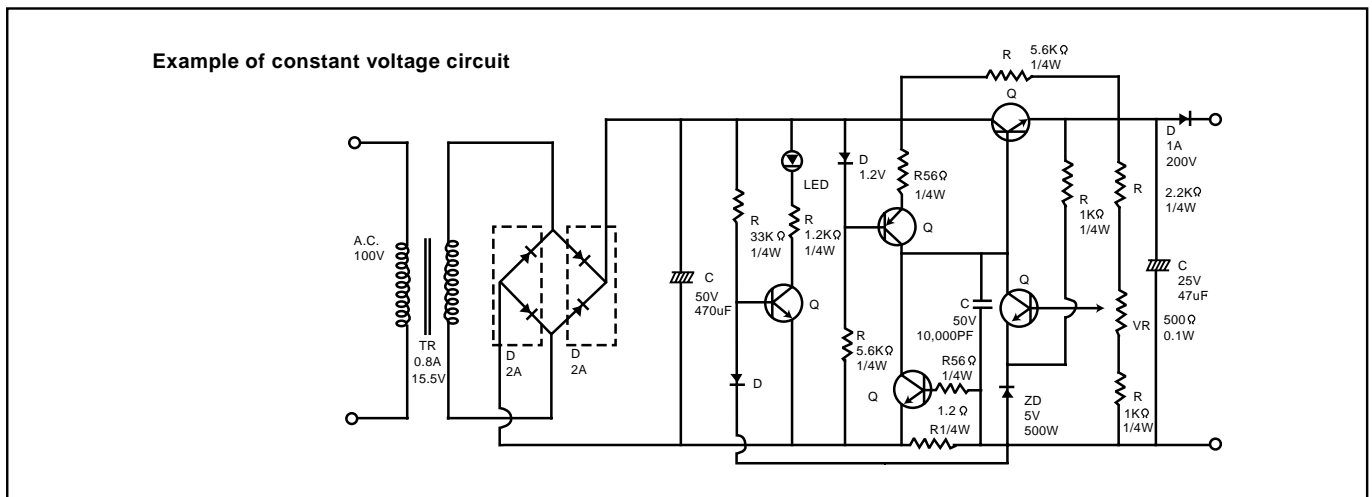

Precautions

- When adopting charging methods and charging conditions other than those described in the specifications or the brochures, thoroughly check charging/discharging characteristics and life characteristics of the battery in advance. Selection of appropriate methods and conditions of charging is essential for safe use of the battery and for fully utilizing its discharge characteristics.
- In cyclic use of the battery, use a charger equipped with a charging timer or a charger in which charging time or charge amount is controlled by other means; otherwise, it will be difficult to judge the completion of the charge. Use of a charger as described above is recommended to prevent undercharge or overcharge which may cause deterioration of the battery characteristics.
- Continue charging the battery for the specified time or until the charge completion lamp, if equipped, indicates completion of charging. Interruption of charging may cause a shortening of service life.
- Do not recharge the fully charged battery repeatedly, as overcharge may accelerate deterioration of the battery.
- In cyclic use of the battery, do not continue charging for 24 hours or longer, as it may accelerate deterioration of the battery.
- In cyclic service of the battery, avoid charging two or more batteries connected in parallel simultaneously: imbalance of charge/discharge amount among the batteries may shorten the life of batteries.

SAFETY DESIGN

- **Vent (One way valve)**
If the internal pressure of the battery is raised to an abnormal level, the rubber one way valve opens to release excessive pressure; thus the valve protects the battery from danger of bursting. Since the rubber valve is instantly resealable, the valve can perform its function repeatedly whenever required.
- **Example of Valve Construction**

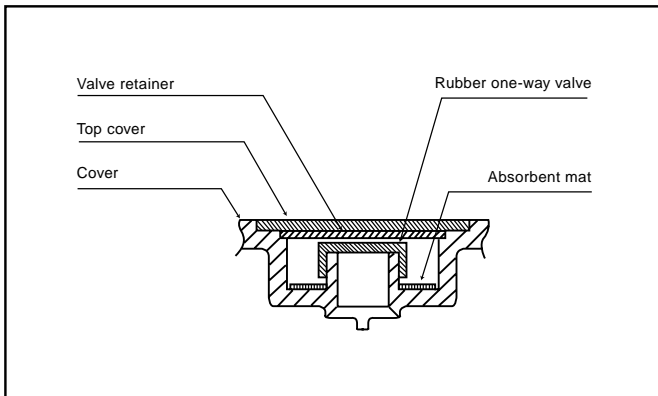

SAFETY

VRLA battery safety test items

| Item | Test method | Check point |
|---------------------------------|--|---|
| 1. Shock test (Drop test) | A fully charged battery is allowed to drop in the upright position from the height of 20 cm onto a hard board having a thickness of 10 mm or more. Test is repeated three times. | The battery should be free from noticeable breakage or leaks; and its terminal voltage should be held higher than the nominal voltage. |
| 2. Vibration test | A vibration frequency 1000 times/minute and amplitude 4 mm is applied to the X-, Y- and Z-axis directions of a fully charged battery for 60 minutes respectively. | No battery part should be broken; the battery should be free from leaks; and its terminal voltage should be held higher than the nominal voltage. |
| 3. Oven test | A fully charged battery is left standing in an atmosphere of 70°C for 10 hours. | The battery case should not be deformed; the battery should be free from leaks. |
| 4. Coldproof test | A fully charged battery is connected to a resistor equivalent to 60 hour rate discharge and left for 4 days; then the battery is left standing in an atmosphere of -30°C for 24 hours. | No crack should develop in the battery case; the battery should be free from leaks. |
| 5. Heat cycle test | A fully charged battery is exposed to 10 cycles of 2 hours at -40°C and 2 hours at 65°C. | No crack should develop in the battery case; the battery should be free from leaks. |
| 6. Short circuit test | A fully charged battery connected with a small resistor of 10 ohms or less is allowed to discharge. | The battery must not burn nor burst. |
| 7. Large current discharge test | A fully charged battery is allowed to discharge at 3CA to 4.8V / 6V battery level. (This test is not applicable to batteries having built-in thermostat.) | The battery must not burn nor burst, and it should be free from battery case deformation, leaks and any irregularity in the internal connections. |
| 8. Vent valve function test | A fully charged battery is submerged in liquid paraffin in a container, then overcharged at 0.4 CA. (UL1989) | Release of gas from the vent should be observed. |
| 9. Overcharge test | A fully charged battery is overcharged at 0.1 CA for 48 hours, left standing for one hour, and allowed to discharge at 0.05CA to 5.25V / 6V battery level. | No irregularity should be noticed in the battery appearance; the battery should retain 95 % or more of the initial capacity. |

(Note) The above safety notes apply only to standalone batteries, not to embedded batteries.

MODEL NUMBERS OF VRLA-BATTERIES

Composition of Model Numbers.

| | | | | | | | | | | | | |
|------------|---|---|---|---|---|---|---|---|---|----|----|----|
| Figure No. | 1 | 2 | 3 | 4 | 5 | 6 | 7 | 8 | 9 | 10 | 11 | 12 |
| Model No. | L | C | - | ⊗ | ⊗ | ⊗ | ⊗ | ⊗ | ⊗ | ⊗ | ⊗ | ⊗ |

⊗: Corresponding model number descriptions are listed below.
Please refer to the battery indexes for listings of available models.

No. 1 to 3:

Product division codes (all of which are assigned by Panasonic). "LC" means Panasonic Valve Regulated Lead-Acid batteries.

No. 4:

Fixed single-figure code (alphabetic letter) indicating properties, shape, etc. of the battery

XC : Cycle long life products
 X : Trickle long life products
 P : Products combining trickle long life and flameretardant battery case
 R : Small-sized common products (Under 17Ah)
 L : Medium-sized common products
 V : Products of "R" and "L" types with flameretardant battery case (option)

No. 5:

Single code (alphabetic letter) for dividing products of the same type and the same capacity but having different shapes. (This figure may be omitted when not applicable, then the proceeding codes are advanced.)

Examples:
 LC-RD
 LC-XB

No. 5 to 7:

Double-figure fixed codes indicating nominal voltage by numerical value.

Examples:
 6V = 06, 12V = 12, etc.

No. 7 to 10:

One- through four-figure (maximum) codes indicating capacity by numbers: decimal point is expressed by R (When some codes are not applicable, the proceeding codes are advanced.)

Examples:

| | | | | |
|----------------------------|-----|-------|------|-------|
| Capacity (20 hour rate) | 4Ah | 7.2Ah | 12Ah | 100Ah |
| | ↓ | ↓ | ↓ | ↓ |
| Model Number | 4 | 7R2 | 12 | 100 |

No. 8 to 12:

One- through five-figure (maximum) alphanumeric code for classifying products by terminal type, package form, destination code, etc.

Examples: P: English label
 J: Japanese label
 G: VdS certified products

(Note) 1) Division codes are subject to change.

MODEL NUMBERS OF VRLA-BATTERIES

Composition of Model Numbers.

UP-RW series (High power batteries for UPS)



No. 1 to 3

Production division codes of high power batteries for UPS.

No. 4

Fixed single-figure code (alphabetic letter) indicating properties, shape, etc. of the battery.

R: Buck up power sources series.

No. 5

Standing for Watt.

No. 6

Single alphabetic letter for dividing products of the same type and the same capacity but having different shapes. (This figure may be omitted when not applicable, then the proceeding codes are advanced.)

**Examples: UP-RW
UP-RWA**

No. 6 to 8:

Double-figure fixed codes indicating nominal voltage by numerical value.

Examples: 12V = 12, 24V = 24

No. 8 to 10:

Indicating wattage at 2V, 10 minute rate discharge.

No. 10 to 12:

One-through five-figure (maximum) alphanumeric code for classifying products by terminal type, package form, destination code, etc.

**Examples: J: Japanese label
E: English label
1: Faston 250**

(Note) The last numbers of model number changes depending on the country of destination. Please consult Panasonic for more details. Division codes are subject to change.

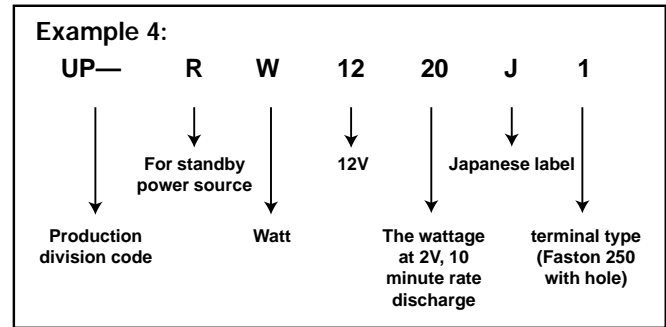
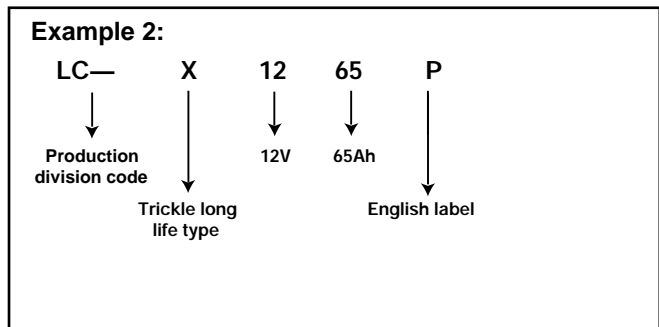
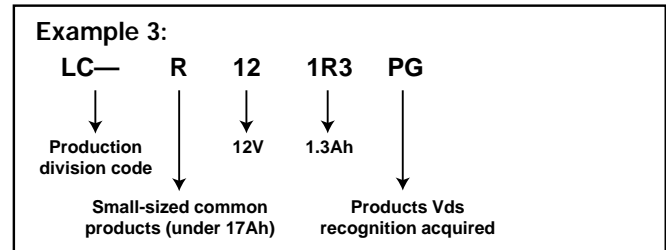
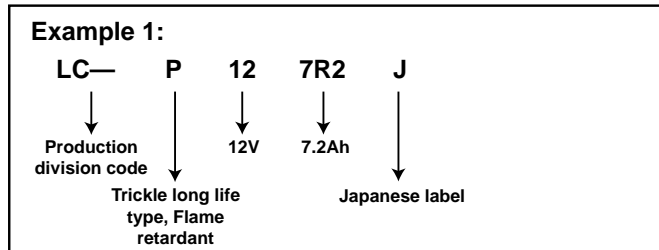

BATTERY SELECTION CHART

Method of battery selection (Estimation of initial discharge time)

- (1) Determine discharge current.
- (2) Determine duration of discharge required.
- (3) Select batteries from the selection chart below.

Then, select a battery which meets the specification of the equipment in which the battery is loaded such as voltage, dimensions and mass, from the "Battery Index" on page 34 to 37.

VRLA battery for main power applications

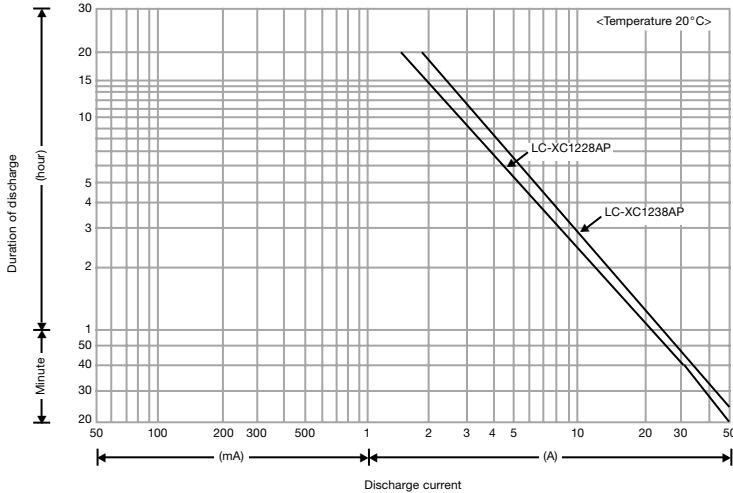

VRLA battery for standby power applications (2.2 Ah to 28 Ah)

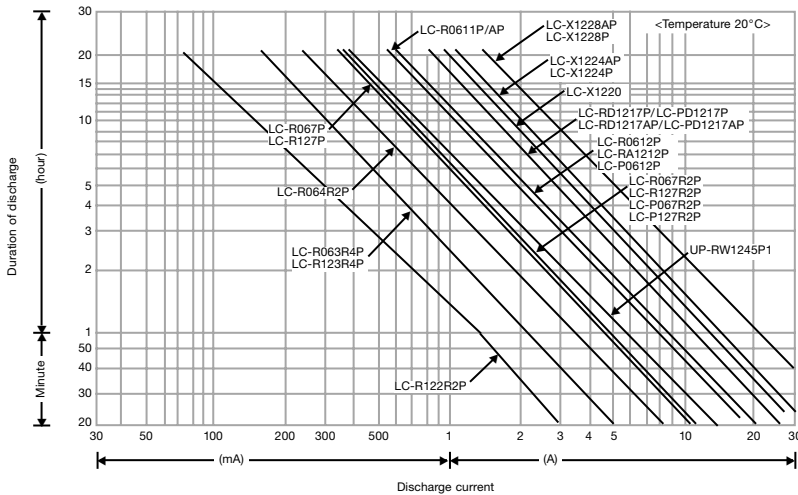

VRLA battery for standby power applications (high-power for UPS)

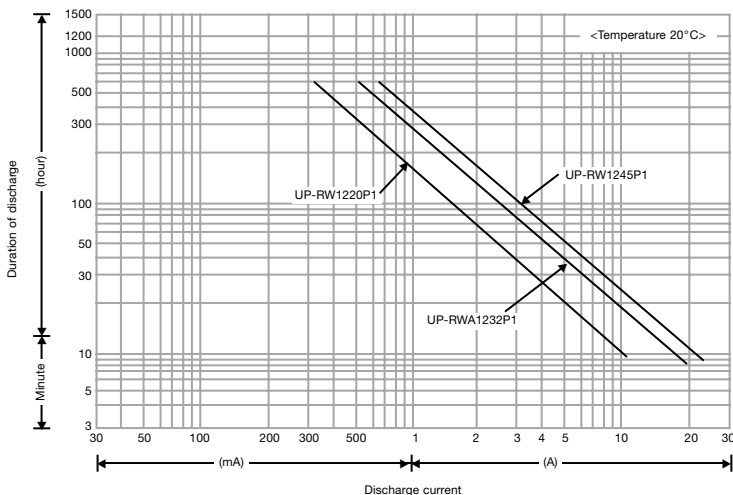

BATTERY SELECTION CHART - CONTINUED

(4) Example

- Use condition: 2.9 A, 1.5 hours, 12 V; space allowable 100 mm x 160 mm x 105 mm
- 7.2 Ah is selected in the step (3).
- LC-R127R2P 94 mm x 151 mm x 100 mm is selected in the step (4).

(5) Refer to individual data sheets for detailed discharge characteristics of the battery.

(Note) Data given are the average values obtained within three cycles of charge/discharge, not the minimum values.

VRLA battery for standby power applications (33 Ah to 65 Ah)

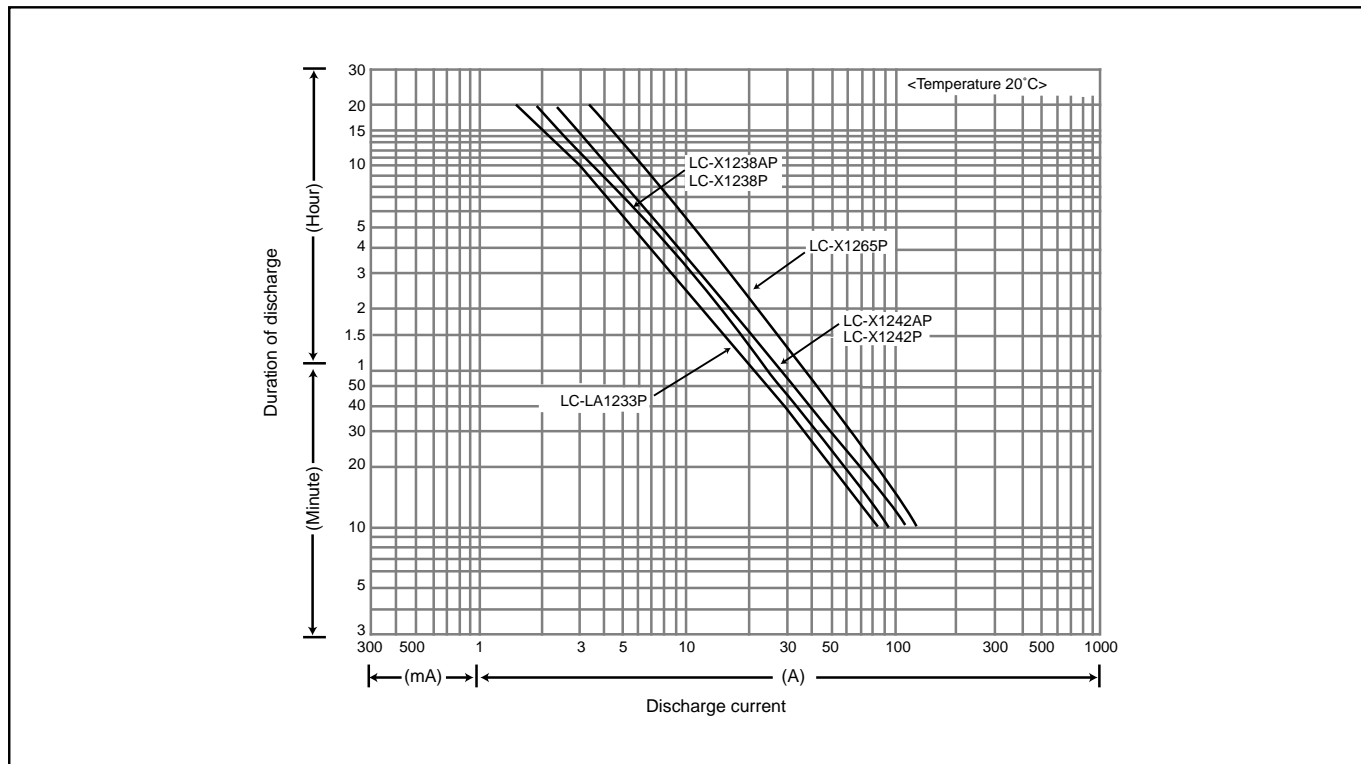

VRLA battery for standby power applications (100 Ah)

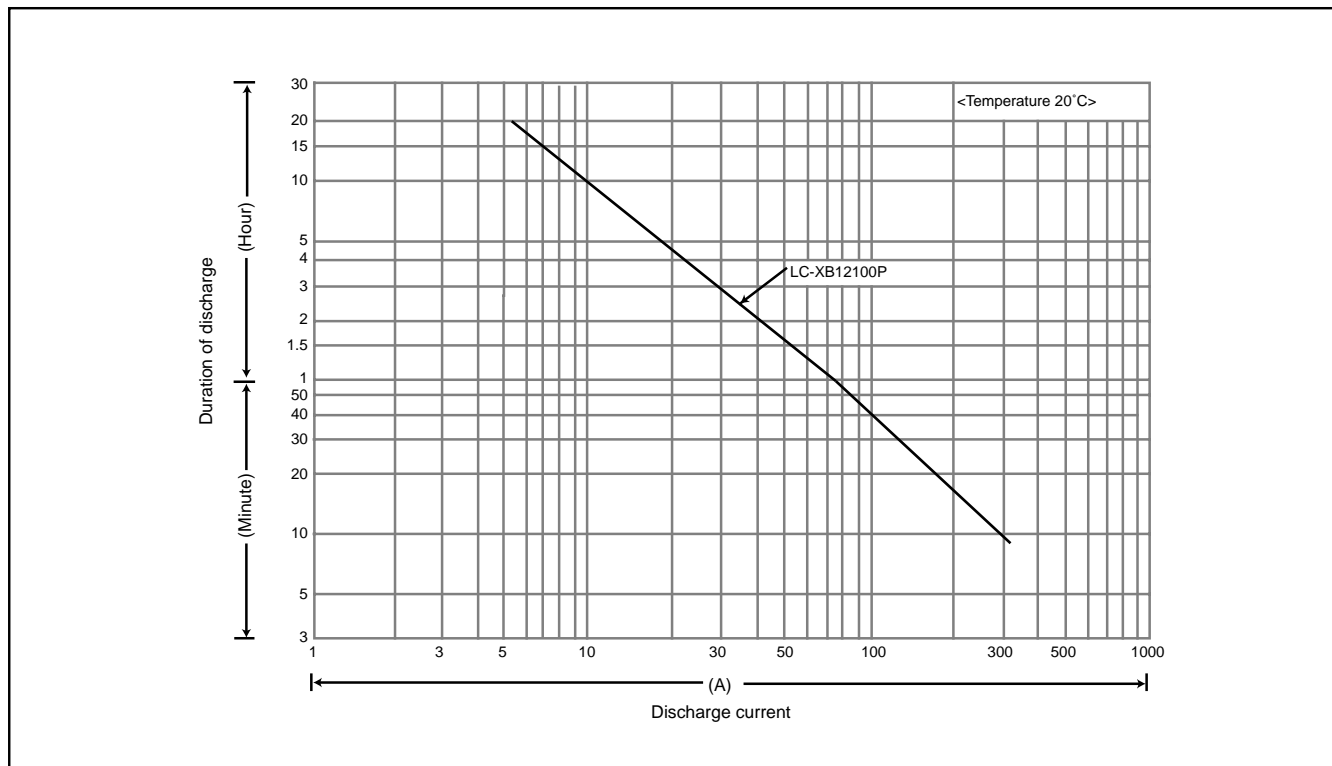

BATTERY SELECTION GUIDE

Steps for selecting batteries are described below.

- Study of required specifications (draft)
Study the required specifications (draft) by

checking the requirements for the battery with the battery selection criteria. Technical requirements for selecting the battery are presented below.

Technical requirements for battery selection

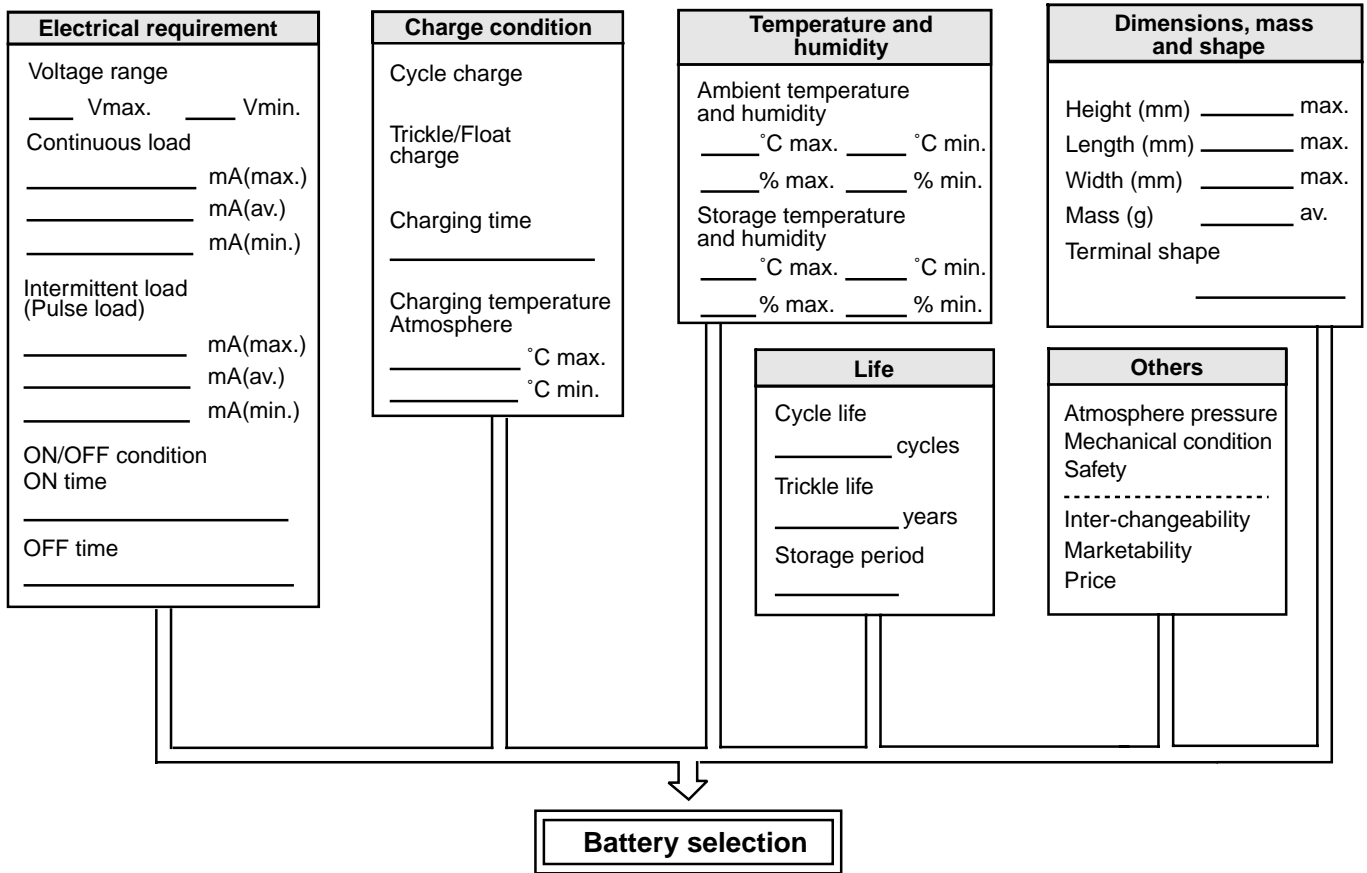

• Battery selection

First, select several candidate batteries by referring to the technical brochures and data sheets of the batteries presently available. Then from the candidates select a battery which can meet as many of the ideal requirements as possible. In fact, however, battery selection can be seldom made so smoothly. Practically, possible removal or easing of the requirements should be considered first; then depending on the result, a proper battery should be selected from those presently available. This way of proceeding enables economic selection of the battery. Any questions at this stage should be asked to battery engineers in depth. Sometimes, new or improved batteries which are not carried in the brochures have become available, and an appropriate battery may be found among them. Usually, required specifications are finalized at this stage.

• Request for improving or developing batteries

If no battery which will satisfy special requirements can be found by the above-described approach, requests for improving or developing new batteries should be made to our technical department, and these requests should be coordinated as quickly as possible to allow enough time for studying: the study takes usually 6 to 12 months or even longer depending on the request.

In this section, guidelines for selecting appropriate batteries for specific equipment were mentioned. If further information regarding the battery selection is required, please contact us.

BATTERIE INDEX...FOR MAIN AND STANDBY POWER SUPPLIES

Standard Type

Trickle Design life approx. 6 years...LC-R, LC-L series

| Model Number | Nominal Voltage (V) | Rated capacity (Ah) (20 hour rate) | Trickle design life (years) at 20°C | Terminal types | Batterie-case resin | | Page |
|--------------|---------------------|------------------------------------|-------------------------------------|------------------------------------|---------------------|---------------------------|------|
| | | | | | Standard (UL94HB) | Flame-retardant (UL94V-O) | |
| LC-R122R2P | 12 | 2.2 | 6 | Faston 187 | √ | | 38 |
| LC-R063R4P | 6 | 3.4 | 6 | Faston 187 | √ | | 39 |
| LC-R123R4P | 12 | 3.4 | 6 | Faston 187 | √ | | 40 |
| LC-R064R2P | 6 | 4.2 | 6 | Faston 187 | √ | | 41 |
| LC-R067P | 6 | 7.0 | 6 | Faston 187 or Faston 250 dimple | √ | | 43 |
| LC-R127P | 12 | 7.0 | 6 | Faston 187 or Faston 250 dimple | √ | | 44 |
| LC-R067R2P | 6 | 7.2 | 6 | Faston 187 or Faston 250 with hole | √ | | 45 |
| LC-R127R2P | 12 | 7.2 | 6 | Faston 187 or Faston 250 with hole | √ | | 47 |
| LC-R0611P | 6 | 11.0 | 6 | Faston 187 or Faston 250 dimple | √ | | 49 |
| LC-R0612P | 6 | 12.0 | 6 | Faston 187 or Faston 250 with hole | √ | | 50 |
| LC-RA1212P | 12 | 12.0 | 6 | Faston 187 or Faston 250 with hole | √ | | 52 |
| LC-LA1233P | 12 | 33.0 | 6 | M6 bolt and nut | √ | | 58 |

| Model Number | Nominal Voltage (V) | Nominal capacity (W) (10 minute rate) | Trickle design life (years) at 20°C | Terminal types | Batterie-case resin | | Page |
|--------------|---------------------|---------------------------------------|-------------------------------------|----------------------|---------------------|---------------------------|------|
| | | | | | Standard (UL94HB) | Flame-retardant (UL94V-O) | |
| UP-RW1220P1 | 12 | 20W/2V | 6 | Faston 250 with hole | √ | | 64 |
| UP-RWA1232P1 | 12 | 32W/2V | 6 | Faston 250 with hole | √ | | 65 |
| UP-RW1245P1 | 12 | 45W/2V | 6 | Faston 250 with hole | √ | | 66 |

- (1) If used cyclically, so that the battery is repeatedly only partially discharged (by less than 30% of its rated capacity) and then recharged, the battery life may be drastically shortened, depending on the discharging conditions. Please consult Panasonic regarding the actual load pattern, recharging method, environmental conditions, etc.
- (2) Contact Panasonic for the country of origin on each battery.

Trickle Long Life Type

Overview

Our valve regulated lead-acid battery “trickle long life” series was developed by studying and analyzing the factors which caused deterioration of conventional batteries in various aspects. Further, whereas conventional batteries needed separate bolts and nuts for connection, medium-capacity (24 to 42Ah) type batteries of this series adopt unique terminals which have been made into bolts (threaded post) for simpler installation and better safety; this makes replacement and connection of the batteries easier.

The safety and reliability of these batteries has been greatly improved through the adoption of flame-retardant resins. (For 7.2Ah and 24 to 100Ah, 94HB-equivalent resin is standard; 94V-0-equivalent resins are also suitable).

Features

- **Much longer trickle life compared with conventional batteries was achieved with the battery footprint unchanged. Expected trickle life in the range from 7.2 to 100 Ah**

| Conventional | This series |
|--|--------------------|
| (discharge rate at 0.1CA) 6 years (at 20°C) | 10 years (at 20°C) |
| (discharge rate at 2CA) approx. 3 years (at 20°C) | 6 years (at 20°C) |

- **For easier installation, the terminal configuration of the medium capacity (24 to 42 Ah) type battery was changed from the lead terminal (which needs separate bolts) to the threaded post terminal.**

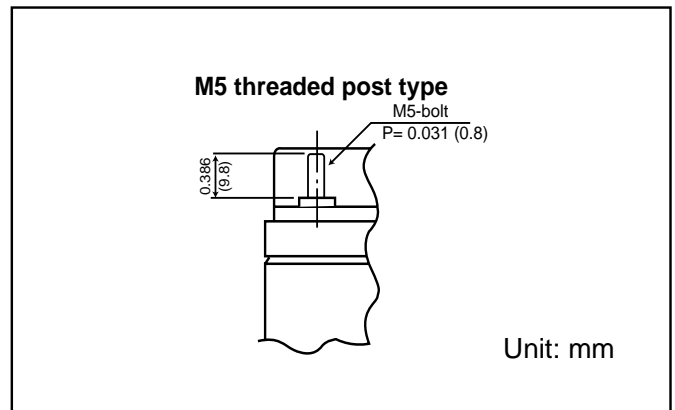

BATTERIE INDEX...FOR MAIN POWER SUPPLIES

Trickle Long Life Type

Trickle Design life approx. 10 years...LC-P, LC-X series

| Model Number | Nominal Voltage (V) | Rated capacity (Ah) (20 hour rate) | Trickle design life (years) at 20°C | Terminal types | Batterie-case resin | | Page |
|--------------|---------------------|------------------------------------|-------------------------------------|------------------------------------|---------------------|---------------------------|------|
| | | | | | Standard (UL94HB) | Flame-retardant (UL94V-O) | |
| LC-P067R2P | 6 | 7.2 | 10 | Faston 187 or Faston 250 with hole | | √ | 46 |
| LC-P0612P | 6 | 12.0 | 10 | Faston 187 or Faston 250 with hole | | √ | 51 |
| LC-P127R2P | 12 | 7.2 | 10 | Faston 187 or Faston 250 with hole | | √ | 48 |
| LC-RD1217AP | 12 | 17.0 | 10 | M5 threaded post | √ | √ | 53 |
| LC-RD1217P | 12 | 17.0 | 10 | M5 bolt and nut | √ | √ | 53 |
| LC-X1220AP | 12 | 20.0 (Nominal capacity) | 10 | M5 threaded post | √ | | 54 |
| LC-X1220P | 12 | 20.0 (Nominal capacity) | 10 | M5 bolt and nut | √ | | 54 |
| LC-X1224AP | 12 | 24.0 | 10 | M5 threaded post | √ | | 55 |
| LC-X1224P | 12 | 24.0 | 10 | M5 bolt and nut | √ | | 55 |
| LC-X1228AP | 12 | 28.0 | 10 | M5 threaded post | √ | | 56 |
| LC-X1228P | 12 | 28.0 | 10 | M6 bolt and nut | √ | | 56 |
| LC-X1238AP | 12 | 38.0 | 10 | M5 threaded post | √ | | 59 |
| LC-X1238P | 12 | 38.0 | 10 | M6 bolt and nut | √ | | 59 |
| LC-X1242AP | 12 | 42.0 | 10 | M5 threaded post | √ | | 61 |
| LC-X1242P | 12 | 42.0 | 10 | M6 bolt and nut | √ | | 61 |
| LC-X1265P | 12 | 65.0 | 10 | M6 bolt and nut | √ | | 62 |
| LC-XB12100P | 12 | 00.0 | 10 | M8 bolt and nut | √ | | 63 |

- (1) If used cyclically, so that the battery is repeatedly only partially discharged (by less than 30% of its rated capacity) and then recharged, the battery life may be drastically shortened, depending on the discharging conditions. Please consult Panasonic regarding the actual load pattern, recharging method, environmental conditions, etc.
- (2) Contact Panasonic for the country of origin on each battery.

BATTERIE INDEX...FOR MAIN POWER SUPPLIES

Cycle Long Life Type

Overview

Our VRLA-battery “cycle long-life” type was developed in an effort to reduce the number of battery replacements. This battery can be used as the main power supply for a variety of products, including electric cars and electric lawn mowers.

Features

- **Much longer cycle life**
IEC 896T2 discharge pattern
Conventional approx. 600 cycles
Cycle long life type approx. 1,200 cycles
- **Higher capacity**
24 Ah → 28 Ah (20-hour rate)

| Model Number | Nominal Voltage (V) | Rated capacity (Ah) (20 hour rate) | Trickle design life (years) at 20°C | Terminal types | Batterie-case resin | | Page |
|--------------|---------------------|------------------------------------|-------------------------------------|------------------|---------------------|---------------------------|------|
| | | | | | Standard (UL94HB) | Flame-retardant (UL94V-O) | |
| LC-XC1228AP | 12 | 28.0 | - | M5 threaded post | √ | | 57 |
| LC-XC1228P | 12 | 28.0 | - | M5 bolt and nut | √ | | 57 |
| LC-XC1238AP | 12 | 38.0 | - | M5 threaded post | √ | | 60 |
| LC-XC1238P | 12 | 38.0 | - | M5 bolt and nut | √ | | 60 |

- (1) If used cyclically, so that the battery is repeatedly discharged (less than 30% of its rated capacity) and then recharged, the battery life may be drastically shortened, depending on the discharging conditions. Please consult Panasonic regarding the actual load pattern, recharging method, environmental conditions, etc.
- (2) Contact Panasonic for the country of origin on each battery.

Characteristics

- **An example of cycle life at 20°C (LC-XC1228AP/LC-XC1228P)**

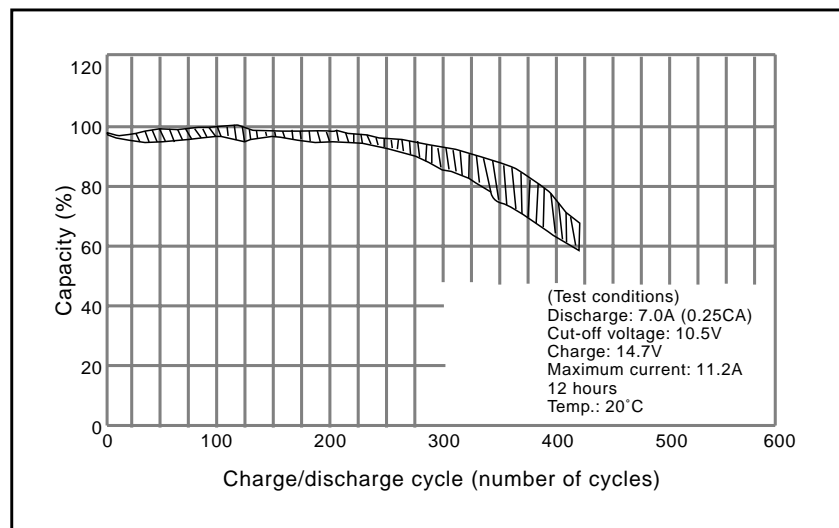

LC-R122R2P



For main and standby power supplies.
Trickle Design: 6 years at 20°C.

Dimensions (mm)

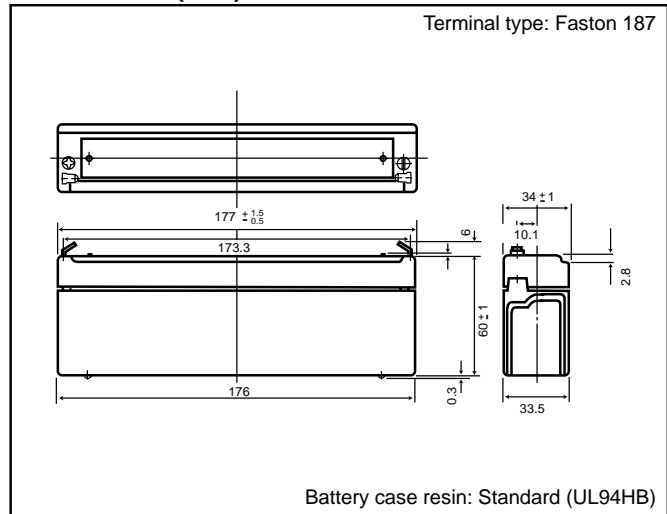

Specifications

| | | |
|-------------------------------|--------------|--------|
| Nominal voltage | 12V | |
| Rated capacity (20 hour rate) | 2.2Ah | |
| Dimensions | Length | 177 mm |
| | Width | 34 mm |
| | Height | 60 mm |
| | Total Height | 66 mm |
| Approx. mass | 0.8 kg | |

Characteristics

| | | |
|---|---|--------------|
| Capacity (note) (20°C) | 20 hour rate (110mA) | 2.20Ah |
| | 10 hour rate (200mA) | 2.00Ah |
| | 5 hour rate (360mA) | 1.80Ah |
| | 1 hour rate (1300mA) | 1.30Ah |
| | 1.5 hour rate discharge Cut-off voltage 10.5 V | 0.95A |
| Internal resistance | Fully charged battery (20°C) | Approx. 70mΩ |
| Temperature dependency of capacity (20 hour rate) | 40°C | 102% |
| | 20°C | 100% |
| | 0°C | 85% |
| | -15°C | 65% |
| Self discharge (20 C) | Residual capacity after standing 3 months | 91% |
| | Residual capacity after standing 6 months | 83% |
| | Residual capacity after standing 12 months | 66% |

(Note) The above characteristics data are average values obtained within three charge/discharge cycles, not the minimum values.

Discharge characteristics (20°C) (Note)

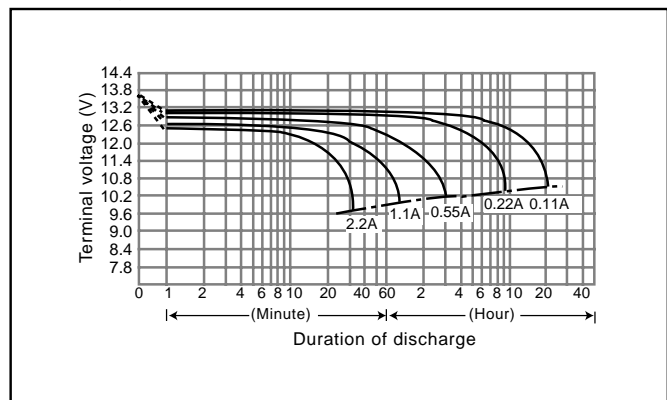

Duration of discharge vs. Discharge current (Note)

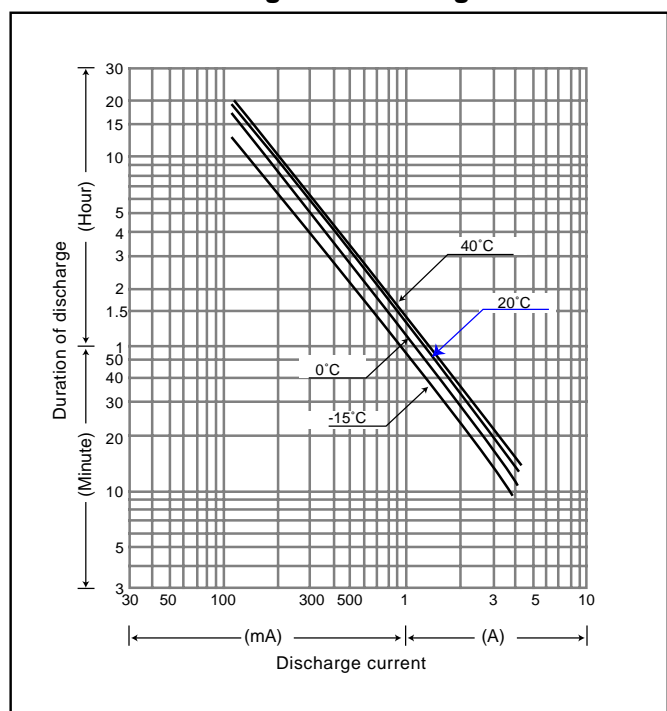

LC-R063R4P



For main and standby power supplies.
Trickle Design life: 6 years at 20°C

Dimensions (mm)

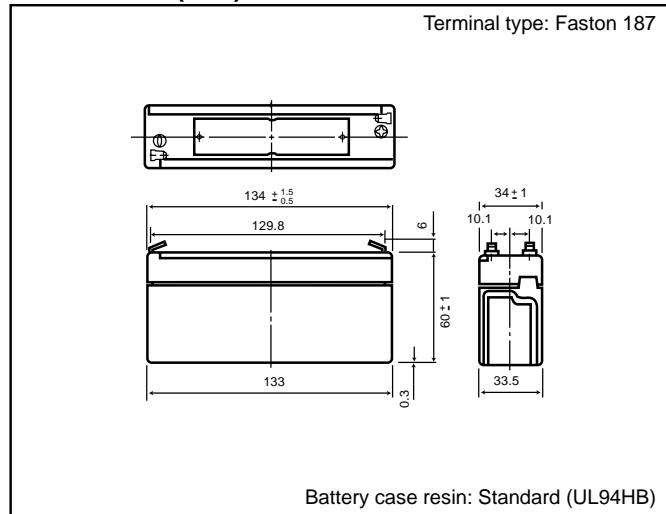

Specifications

| | | |
|-------------------------------|--------------|--------|
| Nominal voltage | 6V | |
| Rated capacity (20 hour rate) | 3.4Ah | |
| Dimensions | Length | 134 mm |
| | Width | 34 mm |
| | Height | 60 mm |
| | Total Height | 66 mm |
| Approx. mass | 0.62 kg | |

Characteristics

| | | |
|---|---|--------------|
| Capacity (note) (20°C) | 20 hour rate (170mA) | 3.40Ah |
| | 10 hour rate (300mA) | 3.00Ah |
| | 5 hour rate (540mA) | 2.70Ah |
| | 1 hour rate (2100mA) | 2.10Ah |
| | 1.5 hour rate discharge Cut-off voltage 5.25 V | 1.5A |
| Internal resistance | Fully charged battery (20°C) | Approx. 30mΩ |
| Temperature dependency of capacity (20 hour rate) | 40°C | 102% |
| | 25°C | 100% |
| | 0°C | 85% |
| | -15°C | 65% |
| Self discharge (20°C) | Residual capacity after standing 3 months | 91% |
| | Residual capacity after standing 6 months | 83% |
| | Residual capacity after standing 12 months | 66% |

(Note) The above characteristics data are average values obtained within three charge/discharge cycles, not the minimum values.

Discharge characteristics (20°C) (Note)

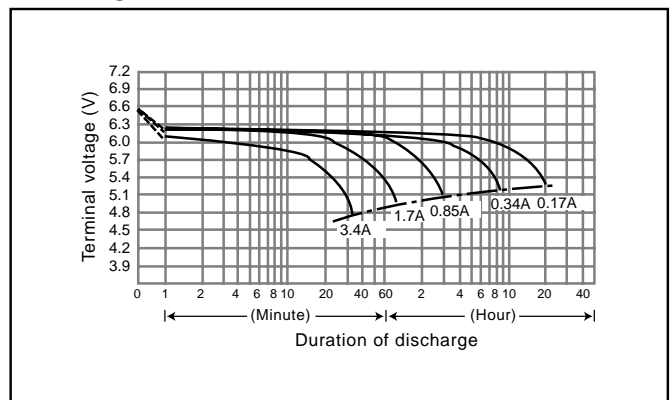

Duration of discharge vs. Discharge current (Note)

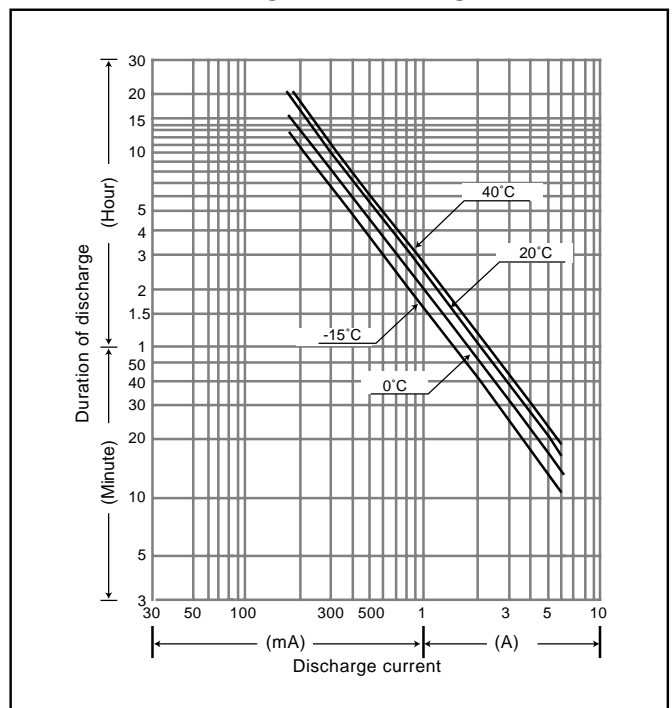

LC-R123R4P



For main and standby power supplies.
Trickle Design life: 6 years at 20°C.

Dimensions (mm)

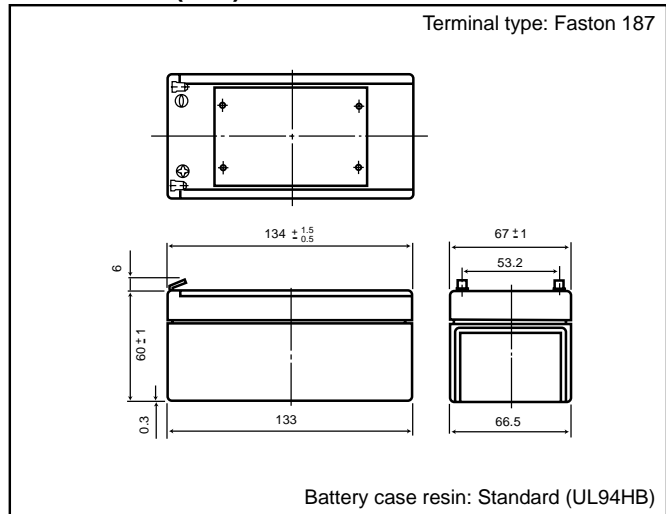

Specifications

| | | |
|-------------------------------|--------------|--------|
| Nominal voltage | | 12V |
| Rated capacity (20 hour rate) | | 3.4Ah |
| Dimensions | Length | 134 mm |
| | Width | 67 mm |
| | Height | 60 mm |
| | Total Height | 66 mm |
| Approx. mass | | 1.2 kg |

Characteristics

| | | | |
|---------------------------|---|--------------|------|
| Capacity (note) (20°C) | 20 hour rate (170mA) | 3.40Ah | |
| | 10 hour rate (300mA) | 3.00Ah | |
| | 5 hour rate (540mA) | 2.70Ah | |
| | 1 hour rate (2100mA) | 2.10Ah | |
| | 1.5 hour rate discharge Cut-off voltage 10.5 V | 1.5A | |
| Internal resistance | Fully charged battery (20°C) | Approx. 60mΩ | |
| | Temperature dependency of capacity (20 hour rate) | 40°C | 102% |
| | | 25°C | 100% |
| | | 0°C | 85% |
| | | -15°C | 65% |
| Self discharge (20°C) | Residual capacity after standing 3 months | 91% | |
| | Residual capacity after standing 6 months | 83% | |
| | Residual capacity after standing 12 months | 66% | |

(Note) The above characteristics data are average values obtained within three charge/discharge cycles, not the minimum values.

Discharge characteristics (20°C) (Note)

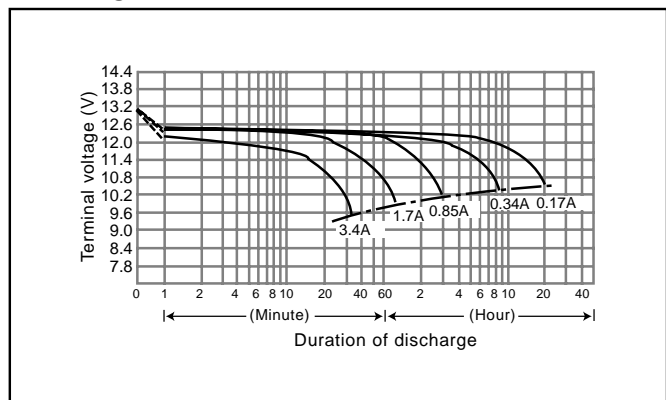

Duration of discharge vs. Discharge current (Note)

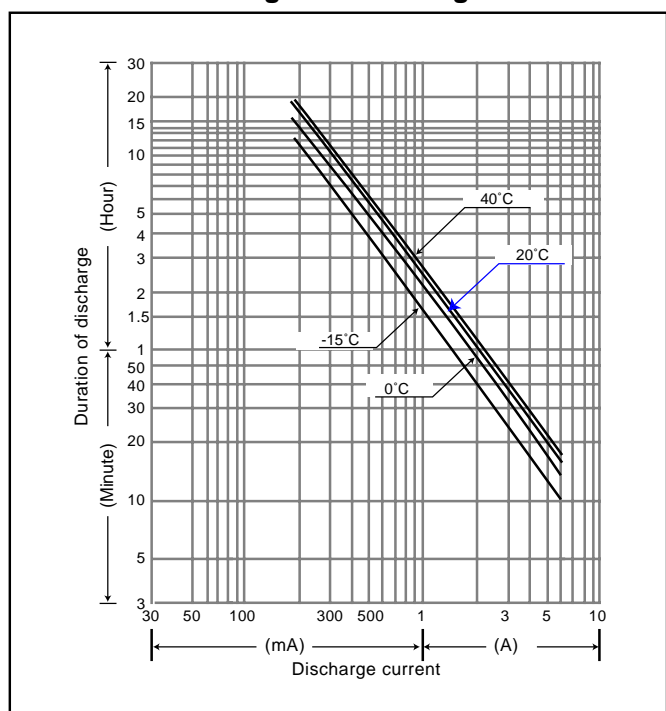

LC-R064R2P

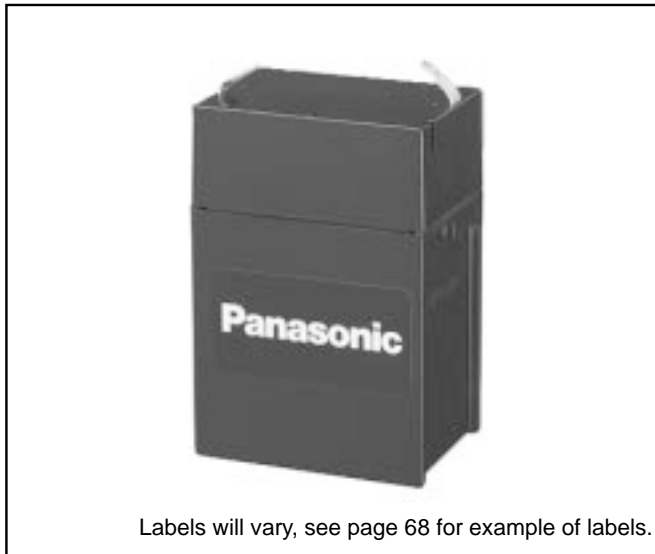

For main and standby power supplies.
Trickle Design life: 6 years at 20°C.

Dimensions (mm)

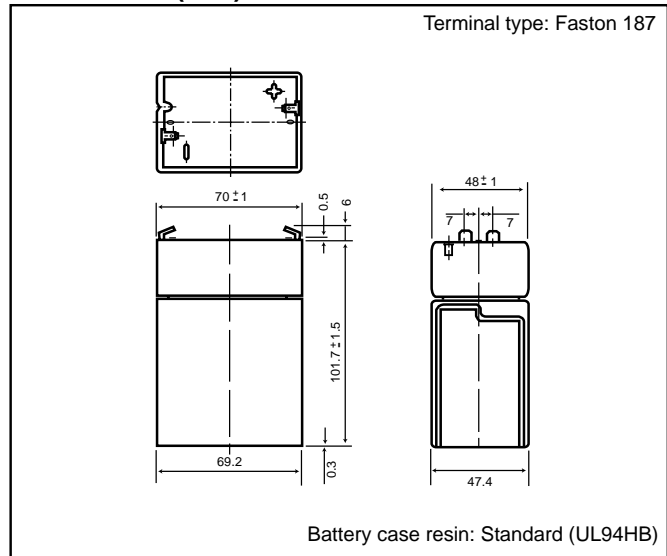

Specifications

| | | |
|-------------------------------|--------------|---------|
| Nominal voltage | | 6V |
| Rated capacity (20 hour rate) | | 4.2Ah |
| Dimensions | Length | 70 mm |
| | Width | 48 mm |
| | Height | 102 mm |
| | Total Height | 108 mm |
| Approx. mass | | 0.78 kg |

Discharge characteristics (20°C) (Note)

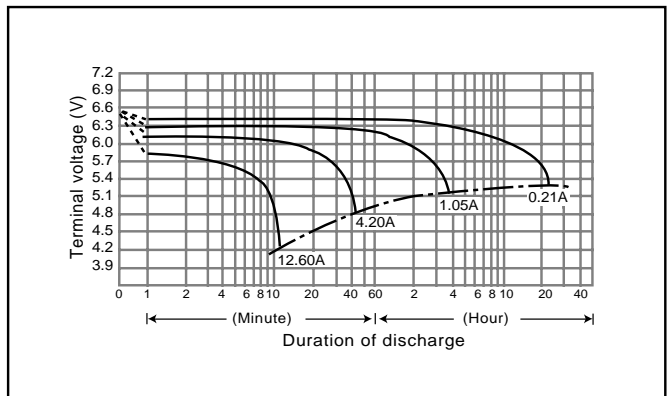

Characteristics

| | | |
|--|---|--------------|
| Capacity (note) (20°C) | 20 hour rate (210mA) | 4.2Ah |
| | 10 hour rate (390mA) | 3.9Ah |
| | 5 hour rate (700mA) | 3.5Ah |
| | 1 hour rate (2800mA) | 2.8Ah |
| | 1.5 hour rate discharge Cut-off voltage 5.25 V | 2.2A |
| Internal resistance | Fully charged battery (20°C) | Approx. 20mΩ |
| Temperature dependency of capacity (20 hour rate) | 40°C | 102% |
| | 20°C | 100% |
| | 0°C | 85% |
| | -15°C | 65% |
| Self discharge (20°C) | Residual capacity after standing 3 months | 91% |
| | Residual capacity after standing 6 months | 83% |
| | Residual capacity after standing 12 months | 66% |

(Note) The above characteristics data are average values obtained within three charge/discharge cycles, not the minimum values.

Duration of discharge vs. Discharge current (Note)

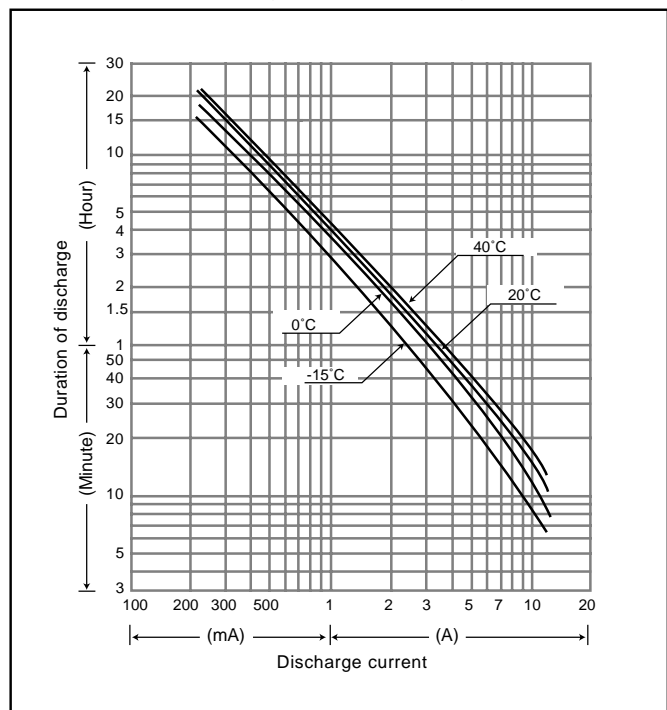

LC-R124R2P



Specifications

| | | |
|-------------------------------|--------------|---------|
| Nominal voltage | | 12V |
| Rated capacity (20 hour rate) | | 4.2Ah |
| Dimensions | Length | 70 mm |
| | Width | 97 mm |
| | Height | 102 mm |
| | Total Height | 108 mm |
| Approx. mass | | 1.56 kg |

Characteristics

| | | |
|---|---|-------------|
| Capacity (note) (20°C) | 20 hour rate (210mA) | 4.2Ah |
| | 10 hour rate (390mA) | 3.9Ah |
| | 5 hour rate (700mA) | 3.5Ah |
| | 1 hour rate (2800mA) | 2.8Ah |
| | 1.5 hour rate discharge Cut-off voltage 5.25 V | 2.2A |
| Internal resistance | Fully charged battery (20°C) | Approx.40mΩ |
| Temperature dependency of capacity (20 hour rate) | 40°C | 102% |
| | 20°C | 100% |
| | 0°C | 85% |
| | -15°C | 65% |
| Self discharge (20°C) | Residual capacity after standing 3 months | 91% |
| | Residual capacity after standing 6 months | 83% |
| | Residual capacity after standing 12 months | 66% |

(Note) The above characteristics data are average values obtained within three charge/discharge cycles, not the minimum values.

For main and standby power supplies.
Trickle Design life: 6 years at 20°C.

Dimensions (mm)

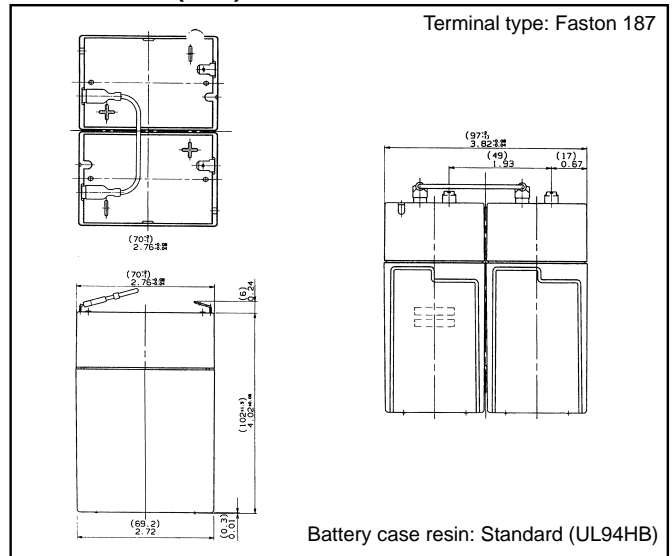

Discharge characteristics (20°C) (Note)

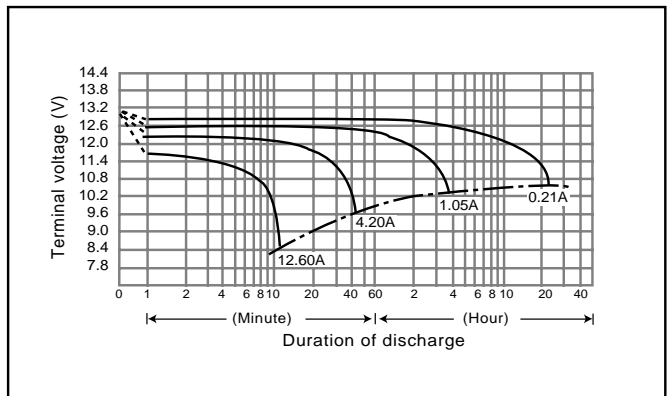

Duration of discharge vs. Discharge current (Note)

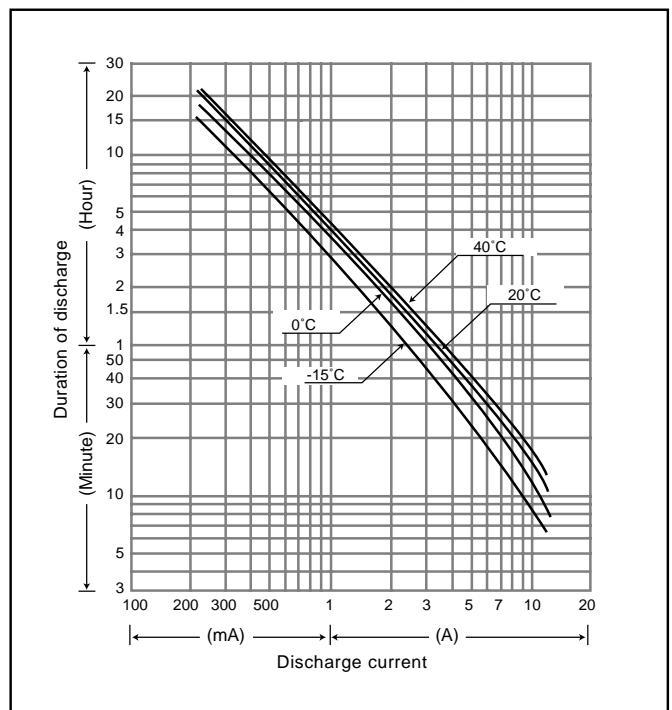

LC-R067P



For main and standby power supplies.
Trickle Design life: 6 years at 20°C.

Dimensions (mm)

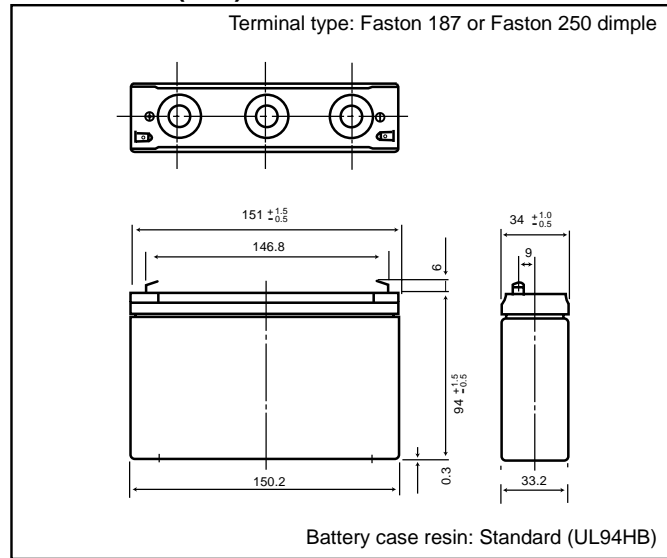

Specifications

| | | |
|-------------------------------|--------------|---------|
| Nominal voltage | | 6V |
| Rated capacity (20 hour rate) | | 7Ah |
| Dimensions | Length | 151 mm |
| | Width | 34 mm |
| | Height | 94 mm |
| | Total Height | 100 mm |
| Approx. mass | | 1.13 kg |

Discharge characteristics (20°C) (Note)

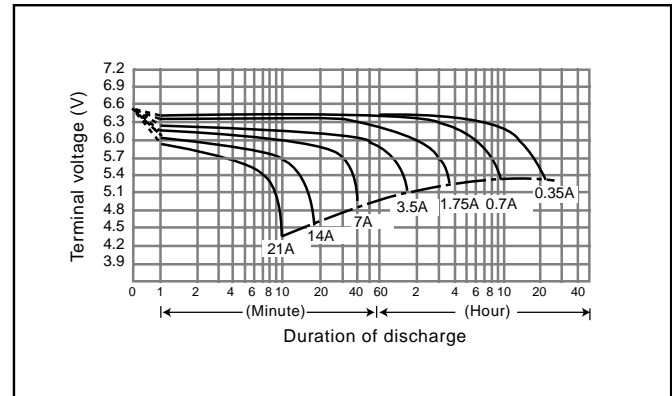

Characteristics

| | | |
|---|---|--------------|
| Capacity (note) (20°C) | 20 hour rate (350mA) | 7.0Ah |
| | 10 hour rate (660mA) | 6.6Ah |
| | 5 hour rate (1220mA) | 6.1Ah |
| | 1 hour rate (4700mA) | 4.7Ah |
| | 1.5 hour rate discharge Cut-off voltage 5.25 V | 3.3A |
| Internal resistance | Fully charged battery (20°C) | Approx. 13mΩ |
| Temperature dependency of capacity (20 hour rate) | 40°C | 102% |
| | 20°C | 100% |
| | 0°C | 85% |
| Self discharge (20°C) | -15°C | 65% |
| | Residual capacity after standing 3 months | 91% |
| | Residual capacity after standing 6 months | 83% |
| | Residual capacity after standing 12 months | 66% |

(Note) The above characteristics data are average values obtained within three charge/discharge cycles, not the minimum values.

Duration of discharge vs. Discharge current (Note)

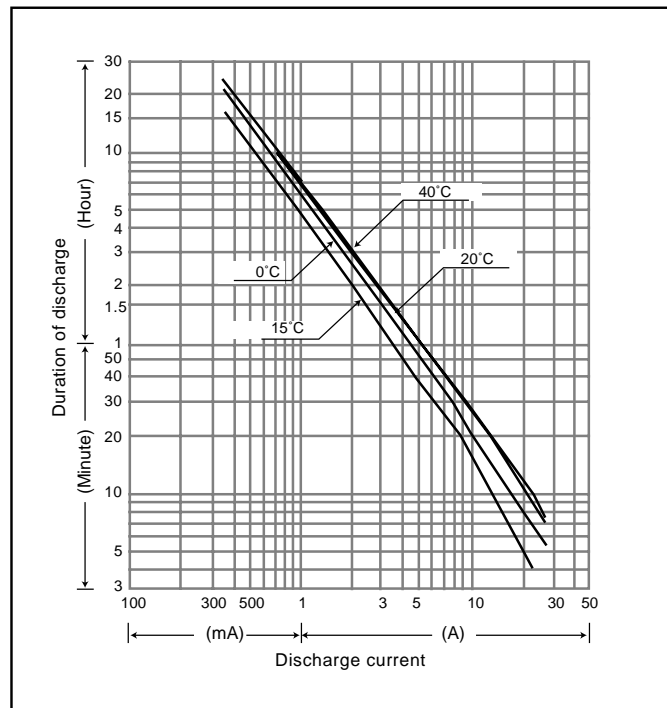

LC-R127P



For main and standby power supplies.
Trickle Design life: 6 years at 20°C.

Dimensions (mm)

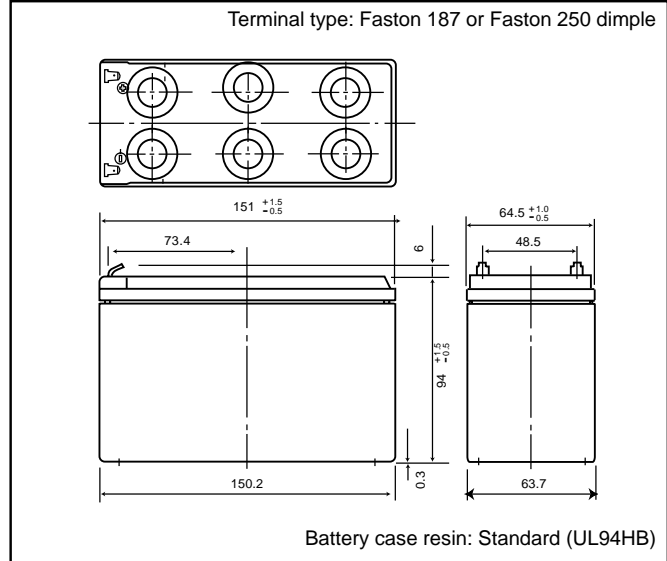

Specifications

| | | |
|-------------------------------|--------------|---------|
| Nominal voltage | 12V | |
| Rated capacity (20 hour rate) | 7Ah | |
| Dimensions | Length | 151 mm |
| | Width | 64.5 mm |
| | Height | 94 mm |
| | Total Height | 100 mm |
| Approx. mass | 2.2 kg | |

Characteristics

| | | |
|---|---|--------------|
| Capacity (note) (20°C) | 20 hour rate (350mA) | 7.0Ah |
| | 10 hour rate (660mA) | 6.6Ah |
| Internal resistance | 5 hour rate (1220mA) | 6.1Ah |
| | 1 hour rate (4700mA) | 4.7Ah |
| | 1.5 hour rate discharge Cut-off voltage 10.5 V | 3.3A |
| Temperature dependency of capacity (20 hour rate) | Fully charged battery (20°C) | Approx. 26mΩ |
| | 40°C | 102% |
| | 20°C | 100% |
| Self discharge (20°C) | 0°C | 85% |
| | -15°C | 65% |
| | Residual capacity after standing 3 months | 91% |
| Self discharge (20°C) | Residual capacity after standing 6 months | 83% |
| | Residual capacity after standing 12 months | 66% |

(Note) The above characteristics data are average values obtained within three charge/discharge cycles, not the minimum values.

Discharge characteristics (20°C) (Note)

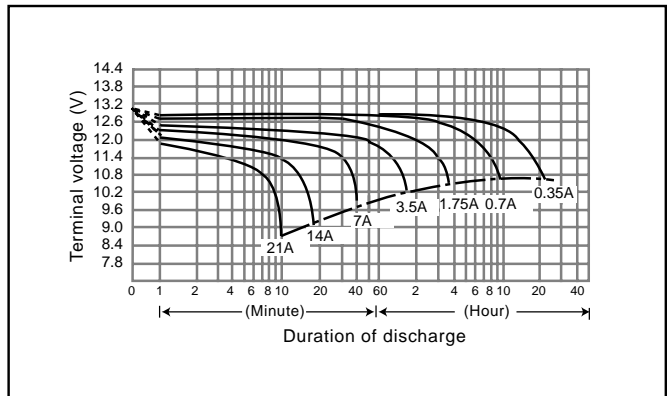

Duration of discharge vs. Discharge current (Note)

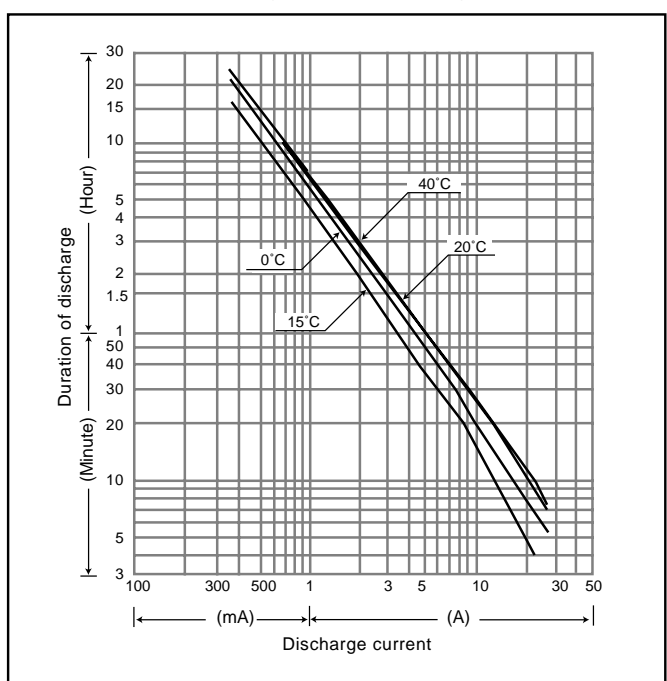

LC-R067R2P



For main and standby power supplies.
Trickle Design life: 6 years at 20°C.

Dimensions (mm)

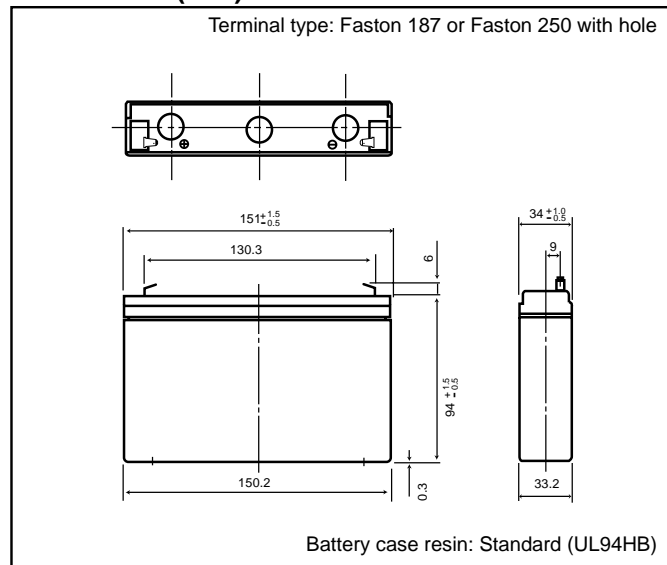

Specifications

| | | |
|-------------------------------|--------------|---------|
| Nominal voltage | | 6V |
| Rated capacity (20 hour rate) | | 7.2Ah |
| Dimensions | Length | 151 mm |
| | Width | 34 mm |
| | Height | 94 mm |
| | Total Height | 100 mm |
| Approx. mass | | 1.26 kg |

* The total height of #250 terminal is 101.5mm.

Discharge characteristics (20°C) (Note)

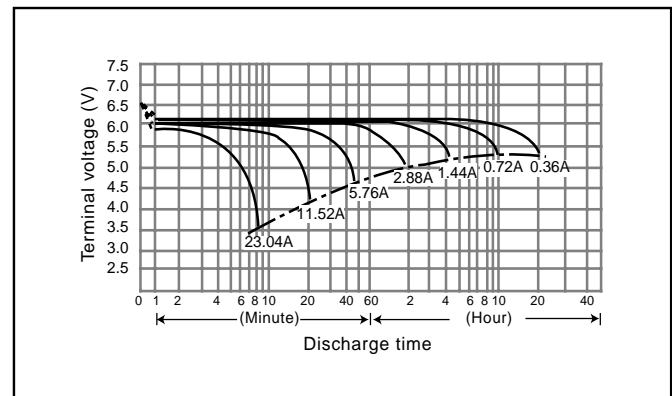

Characteristics

| | | |
|---|---|--------------|
| Capacity (note) (20°C) | 20 hour rate (360mA) | 7.2Ah |
| | 10 hour rate (680mA) | 6.8Ah |
| Internal resistance | 5 hour rate (1260mA) | 6.3Ah |
| | 1 hour rate (4900mA) | 4.9Ah |
| | 1.5 hour rate discharge Cut-off voltage 5.25 V | 3.5A |
| Temperature dependency of capacity (20 hour rate) | Fully charged battery (20°C) | Approx. 20mΩ |
| | 40°C | 102% |
| | 20°C | 100% |
| | 0°C | 85% |
| Self discharge (20°C) | -15°C | 65% |
| | Residual capacity after standing 3 months | 91% |
| | Residual capacity after standing 6 months | 83% |
| | Residual capacity after standing 12 months | 66% |

(Note) The above characteristics data are average values obtained within three charge/discharge cycles, not the minimum values.

Duration of discharge vs. Discharge current (Note)

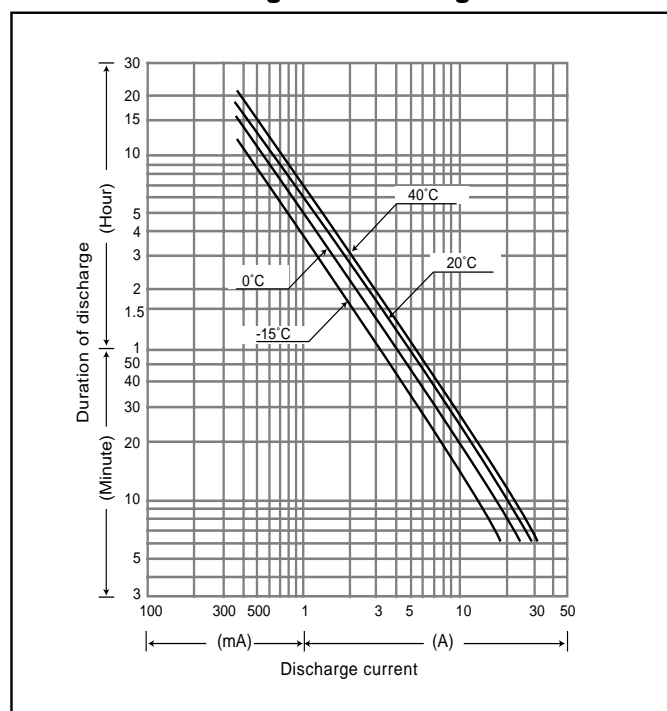

LC-P067R2P



For standby power supplies.
Trickle Design life: 10 years at 20°C.

Dimensions (mm)

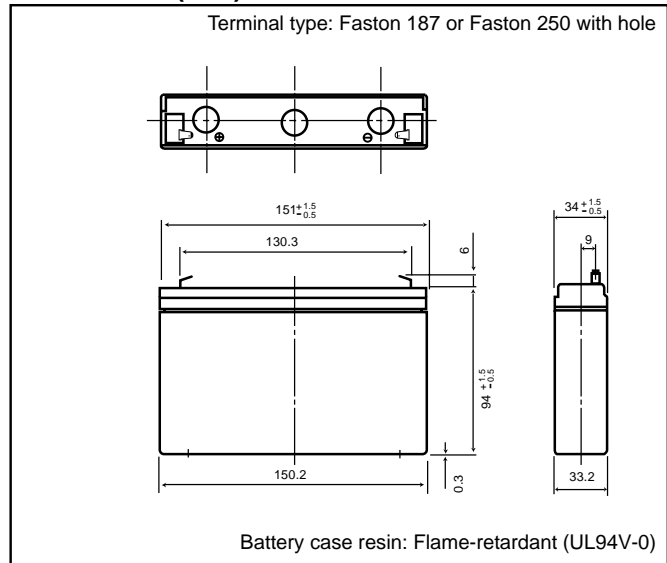

Specifications

| | | |
|-------------------------------|--------------|--------|
| Nominal voltage | | 6V |
| Rated capacity (20 hour rate) | | 7.2Ah |
| Dimensions | Length | 151 mm |
| | Width | 34 mm |
| | Height | 94 mm |
| | Total Height | 100 mm |
| Approx. mass | | 1.3 kg |

* The total height of #250 terminal is 101.5mm.

Characteristics

| | | |
|---|---|--------------|
| Capacity (note) (20°C) | 20 hour rate (360mA) | 7.2Ah |
| | 10 hour rate (680mA) | 6.8Ah |
| | 5 hour rate (1260mA) | 6.3Ah |
| | 1 hour rate (4900mA) | 4.9Ah |
| | 1.5 hour rate discharge Cut-off voltage 5.25 V | 3.5A |
| Internal resistance | Fully charged battery (20°C) | Approx. 20mΩ |
| Temperature dependency of capacity (20 hour rate) | 40°C | 102% |
| | 20°C | 100% |
| | 0°C | 85% |
| | -15°C | 65% |
| Self discharge (20°C) | Residual capacity after standing 3 months | 91% |
| | Residual capacity after standing 6 months | 83% |
| | Residual capacity after standing 12 months | 66% |

(Note) The above characteristics data are average values obtained within three charge/discharge cycles, not the minimum values.

(Note) For cycle use of the battery, please contact us in advance.

Discharge characteristics (20°C) (Note)

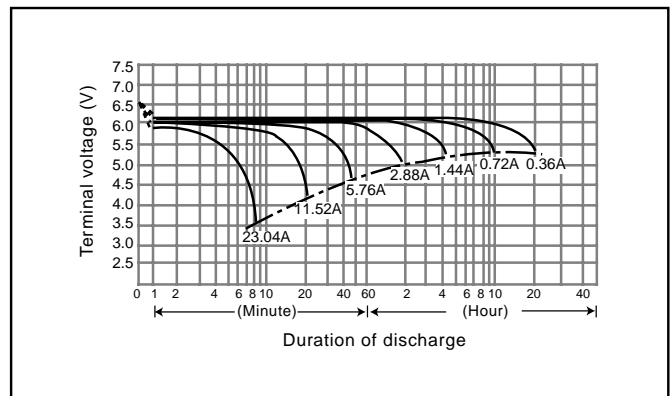

Duration of discharge vs. Discharge current (Note)

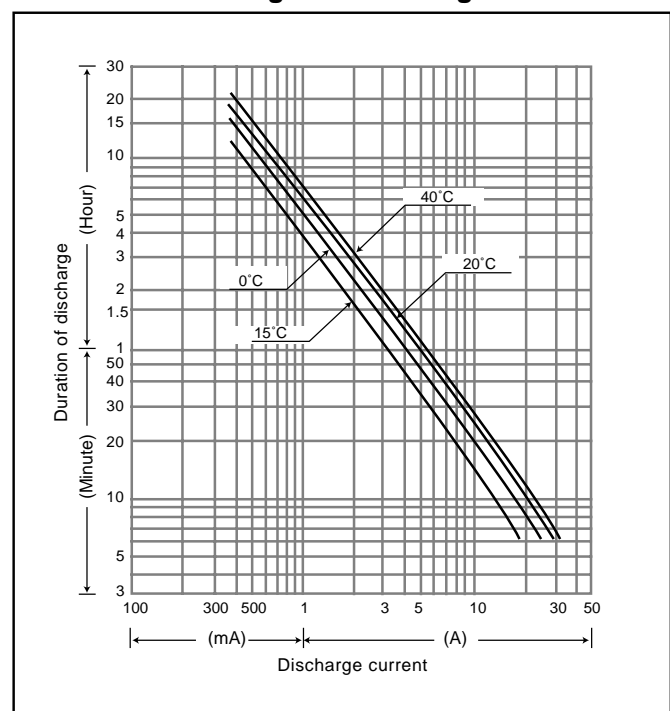

LC-R127R2P

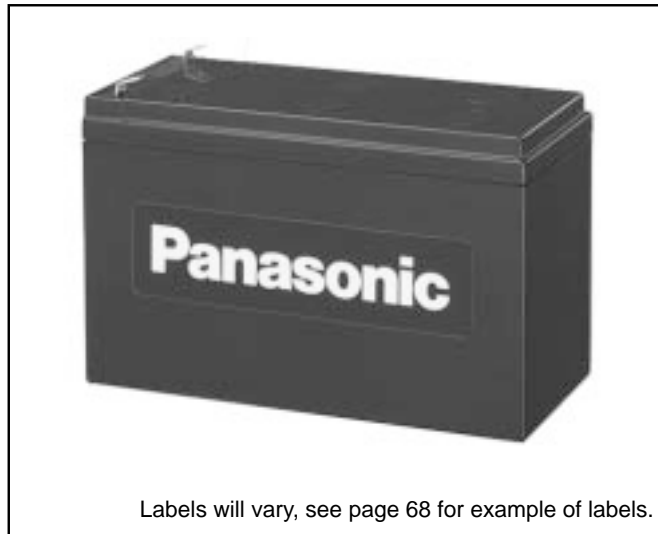

For main and standby power supplies.
Trickle Design life: 6 years at 20°C.

Dimensions (mm)

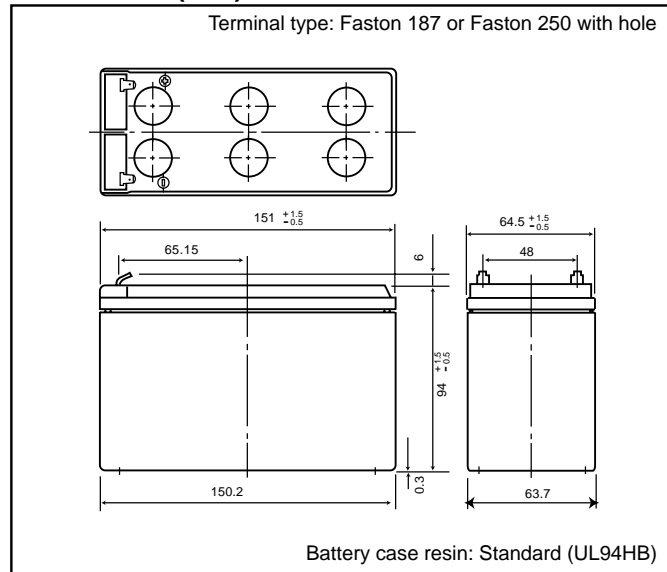

Specifications

| | | |
|-------------------------------|--------------|---------|
| Nominal voltage | | 12V |
| Rated capacity (20 hour rate) | | 7.2Ah |
| Dimensions | Length | 151 mm |
| | Width | 64.5 mm |
| | Height | 94 mm |
| | Total Height | 100 mm |
| Approx. mass | | 2.47 kg |

* The total height of #250 terminal is 101.5mm.

Discharge characteristics (20°C) (Note)

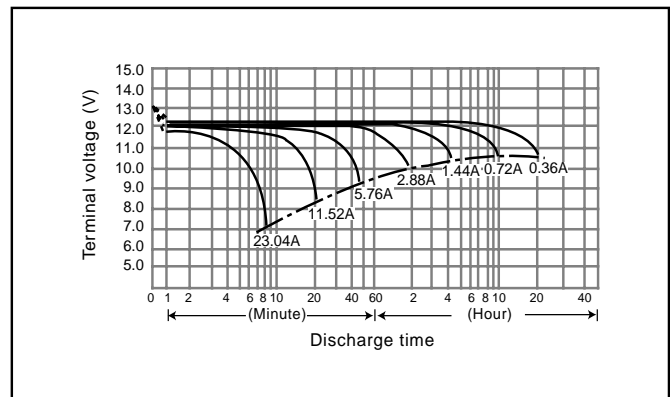

Characteristics

| | | |
|--|---|--------------|
| Capacity (note) (20°C) | 20 hour rate (360mA) | 7.2Ah |
| | 10 hour rate (680mA) | 6.8Ah |
| | 5 hour rate (1260mA) | 6.3Ah |
| | 1 hour rate (4900mA) | 4.9Ah |
| | 1.5 hour rate discharge Cut-off voltage 10.5 V | 3.5A |
| Internal resistance | Fully charged battery (20°C) | Approx. 40mΩ |
| Temperature dependency of capacity (20 hour rate) | 40°C | 102% |
| | 20°C | 100% |
| | 0°C | 85% |
| | -15°C | 65% |
| Self discharge (20°C) | Residual capacity after standing 3 months | 91% |
| | Residual capacity after standing 6 months | 83% |
| | Residual capacity after standing 12 months | 66% |

(Note) The above characteristics data are average values obtained within three charge/discharge cycles, not the minimum values.

Duration of discharge vs. Discharge current (Note)

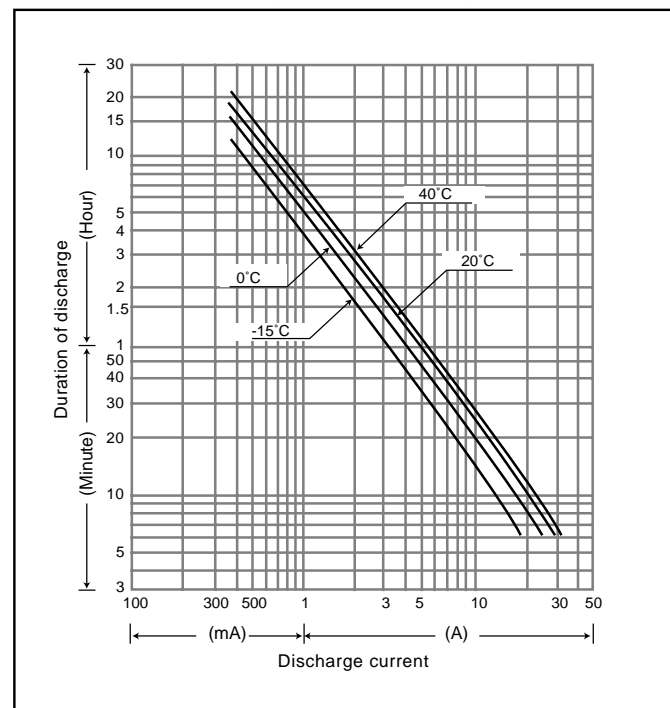

LC-P127R2P



Specifications

| | | |
|-------------------------------|--------------|---------|
| Nominal voltage | | 12V |
| Rated capacity (20 hour rate) | | 7.2Ah |
| Dimensions | Length | 151 mm |
| | Width | 64.5 mm |
| | Height | 94 mm |
| | Total Height | 100 mm |
| Approx. mass | | 2.5 kg |

* The total height of #250 terminal is 101.5mm.

Characteristics

| | | |
|---|---|--------------|
| Capacity (note) (20°C) | 20 hour rate (360mA) | 7.2Ah |
| | 10 hour rate (680mA) | 6.8Ah |
| | 5 hour rate (1260mA) | 6.3Ah |
| | 1 hour rate (4900mA) | 4.9Ah |
| | 1.5 hour rate discharge Cut-off voltage 10.5 V | 3.5A |
| Internal resistance | Fully charged battery (20°C) | Approx. 40mΩ |
| Temperature dependency of capacity (20 hour rate) | 40°C | 102% |
| | 20°C | 100% |
| | 0°C | 85% |
| | -15°C | 65% |
| Self discharge (20°C) | Residual capacity after standing 3 months | 91% |
| | Residual capacity after standing 6 months | 83% |
| | Residual capacity after standing 12 months | 66% |

(Note) The above characteristics data are average values obtained within three charge/discharge cycles, not the minimum values.

(Note) For cycle use of the battery, please contact us in advance.

For standby power supplies.
Trickle Design life: 10 years at 20°C.

Dimensions (mm)

Terminal type: Faston 187 or Faston 250 with hole

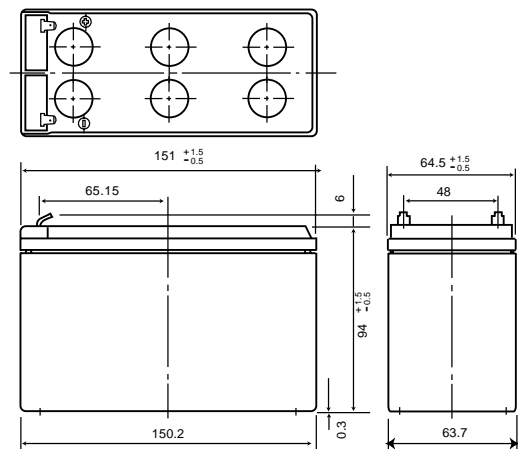

Battery case resin: Flame-retardant (UL94V-0)

Discharge characteristics (20°C) (Note)

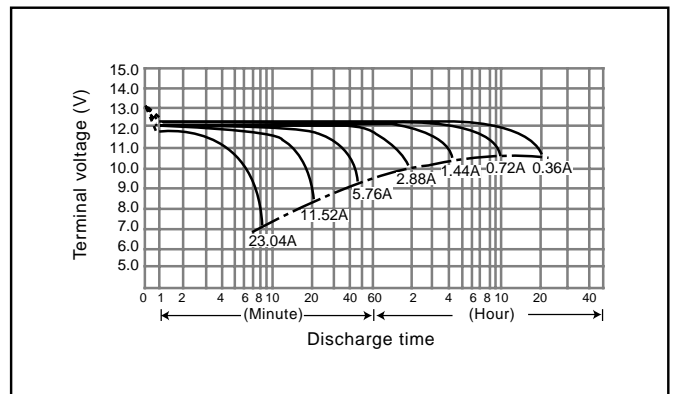

Duration of discharge vs. Discharge current (Note)

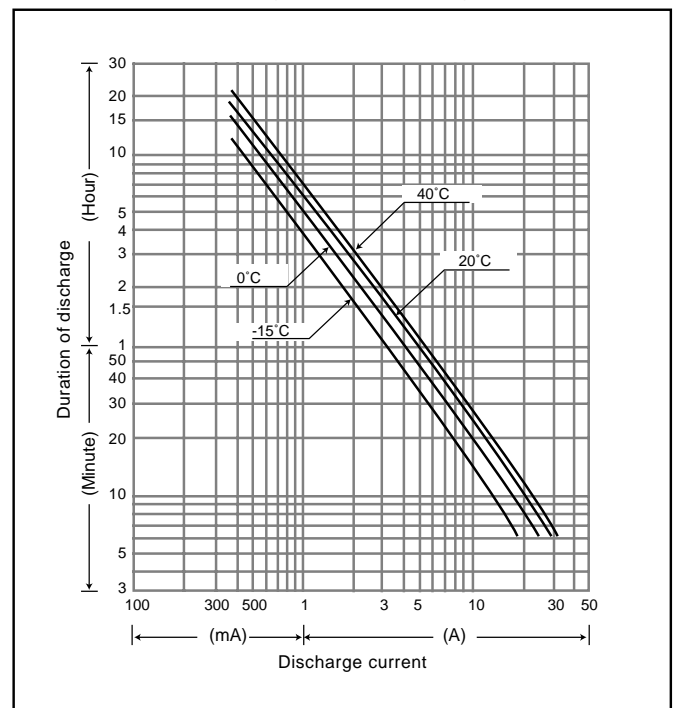

LC-R0611P



For main and standby power supplies.
Trickle Design life: 6 years at 20°C.

Dimensions (mm)

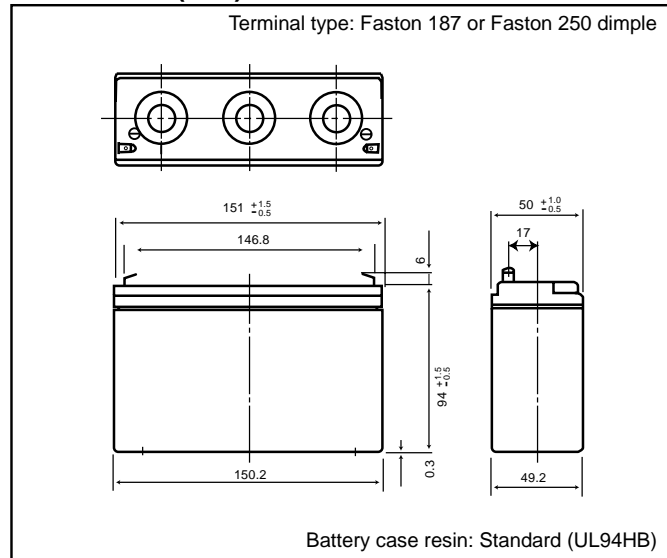

Specifications

| | | |
|-------------------------------|--------------|--------|
| Nominal voltage | | 6V |
| Rated capacity (20 hour rate) | | 11Ah |
| Dimensions | Length | 151 mm |
| | Width | 50 mm |
| | Height | 94 mm |
| | Total Height | 100 mm |
| Approx. mass | | 1.7 kg |

Characteristics

| | | |
|---|---|--------------|
| Capacity (note) (20°C) | 20 hour rate (550mA) | 11.0Ah |
| | 10 hour rate (1040mA) | 10.4Ah |
| | 5 hour rate (1900mA) | 9.5Ah |
| | 1 hour rate (7400mA) | 7.4Ah |
| | 1.5 hour rate discharge Cut-off voltage 5.25 V | 5.3Ah |
| Internal resistance | Fully charged battery (20°C) | Approx. 11mΩ |
| Temperature dependency of capacity (20 hour rate) | 40°C | 102% |
| | 20°C | 100% |
| | 0°C | 85% |
| | -15°C | 65% |
| Self discharge (20°C) | Residual capacity after standing 3 months | 91% |
| | Residual capacity after standing 6 months | 83% |
| | Residual capacity after standing 12 months | 66% |

(Note) The above characteristics data are average values obtained within three charge/discharge cycles, not the minimum values.

Discharge characteristics (20°C) (Note)

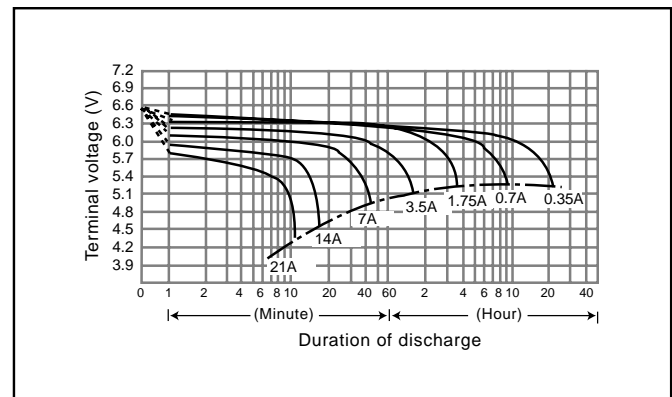

Duration of discharge vs. Discharge current (Note)

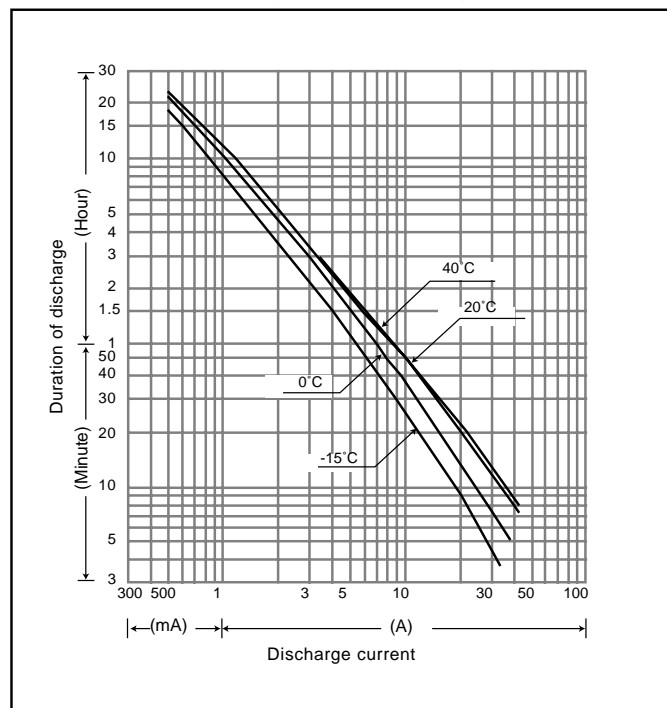

LC-R0612P



Specifications

| | | |
|-------------------------------|--------------|---------|
| Nominal voltage | | 6V |
| Rated capacity (20 hour rate) | | 12Ah |
| Dimensions | Length | 151 mm |
| | Width | 50 mm |
| | Height | 94 mm |
| | Total Height | 100 mm |
| Approx. mass | | 1.95 kg |

* The total height of #250 terminal is 101.5mm.

Characteristics

| | | |
|---|---|--------------|
| Capacity (note) (20°C) | 20 hour rate (600mA) | 12.0Ah |
| | 10 hour rate (1130mA) | 11.3Ah |
| | 5 hour rate (2080mA) | 10.4Ah |
| | 1 hour rate (8100mA) | 8.1Ah |
| | 1.5 hour rate discharge Cut-off voltage 5.25 V | 5.8A |
| Internal resistance | Fully charged battery (20°C) | Approx. 15mΩ |
| Temperature dependency of capacity (20 hour rate) | 40°C | 102% |
| | 20°C | 100% |
| | 0°C | 85% |
| | -15°C | 65% |
| Self discharge (20°C) | Residual capacity after standing 3 months | 91% |
| | Residual capacity after standing 6 months | 83% |
| | Residual capacity after standing 12 months | 66% |

(Note) The above characteristics data are average values obtained within three charge/discharge cycles, not the minimum values.

For main and standby power supplies.
Trickle Design life: 6 years at 20°C.

Dimensions (mm)

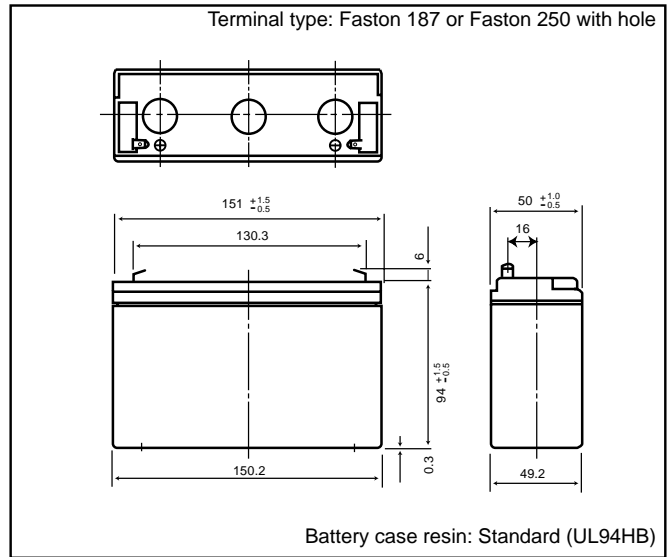

Discharge characteristics (20°C) (Note)

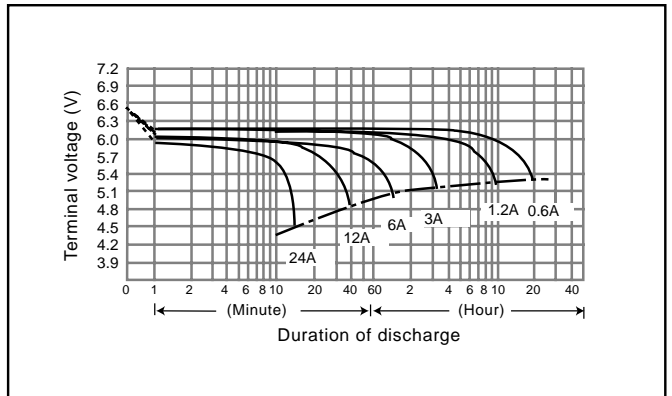

Duration of discharge vs. Discharge current (Note)

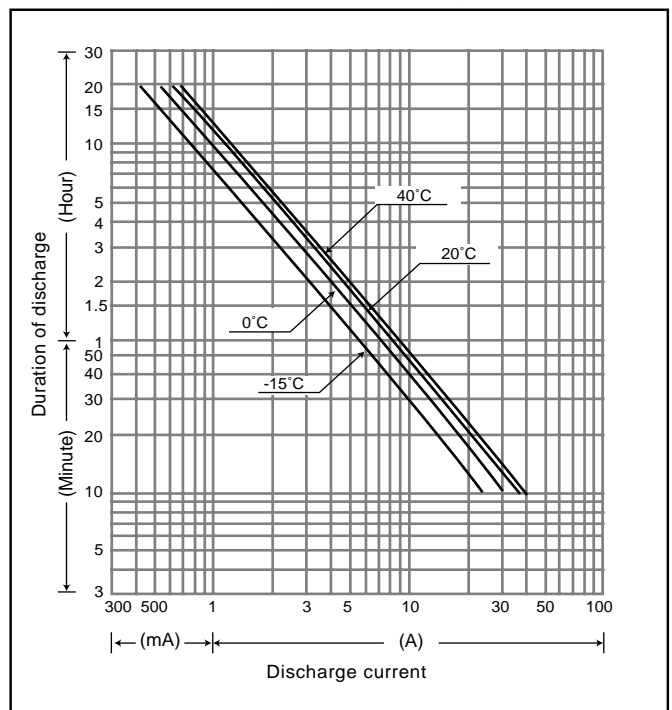

LC-P0612P



Specifications

| | | |
|-------------------------------|--------------|--------|
| Nominal voltage | | 6V |
| Rated capacity (20 hour rate) | | 12Ah |
| Dimensions | Length | 151 mm |
| | Width | 50 mm |
| | Height | 94 mm |
| | Total Height | 100 mm |
| Approx. mass | | 2 kg |

* The total height of #250 terminal is 101.5mm.

Characteristics

| | | |
|--|---|--------------|
| Capacity (note) (20°C) | 20 hour rate (600mA) | 12.0Ah |
| | 10 hour rate (1130mA) | 11.3Ah |
| | 5 hour rate (2080mA) | 10.4Ah |
| | 1 hour rate (8100mA) | 8.1Ah |
| | 1.5 hour rate discharge Cut-off voltage 5.25 V | 5.8A |
| Internal resistance | Fully charged battery (20°C) | Approx. 15mΩ |
| Temperature dependency of capacity (20 hour rate) | 40°C | 102% |
| | 25°C | 100% |
| | 0°C | 85% |
| | -15°C | 65% |
| Self discharge (20°C) | Residual capacity after standing 3 months | 91% |
| | Residual capacity after standing 6 months | 83% |
| | Residual capacity after standing 12 months | 66% |

(Note) The above characteristics data are average values obtained within three charge/discharge cycles, not the minimum values.

(Note) For cycle use of the battery, please contact us in advance.

For standby power supplies.
Trickle Design life: 10 years at 20°C.

Dimensions (mm)

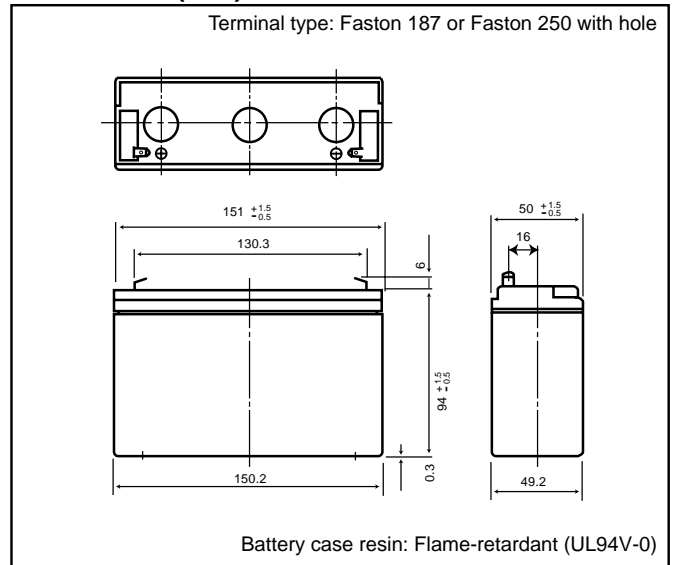

Discharge characteristics (20°C) (Note)

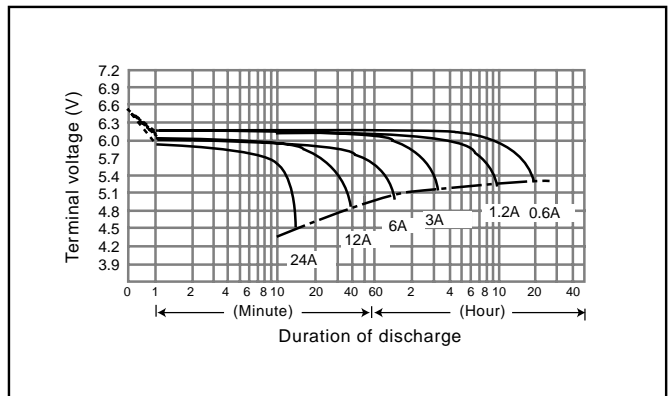

Duration of discharge vs. Discharge current (Note)

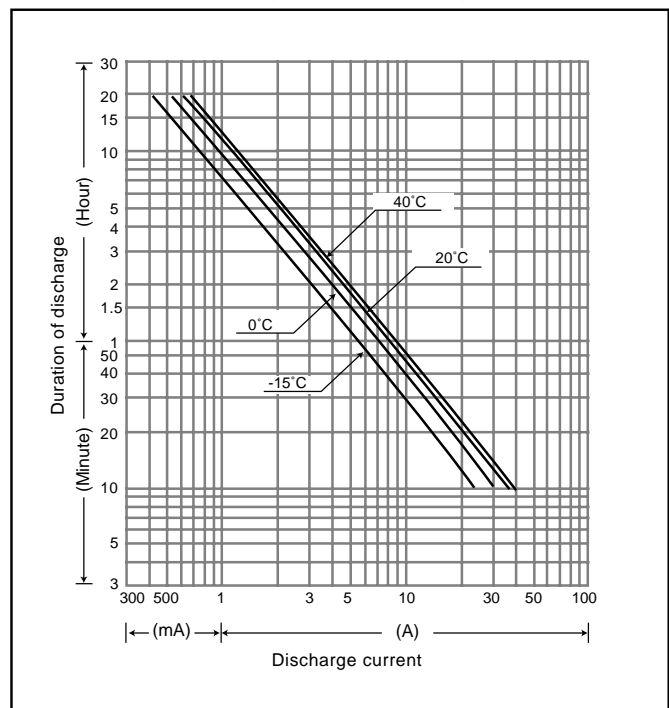

LC-RA1212P



Specifications

| | | |
|-------------------------------|--------------|--------|
| Nominal voltage | | 12V |
| Rated capacity (20 hour rate) | | 12Ah |
| Dimensions | Length | 151 mm |
| | Width | 98 mm |
| | Height | 94 mm |
| | Total Height | 100 mm |
| Approx. mass | | 3.8 kg |

* The total height of #250 terminal is 101.5mm.

Characteristics

| | | |
|---|---|--------------|
| Capacity (note) (20°C) | 20 hour rate (600mA) | 12.0Ah |
| | 10 hour rate (1130mA) | 11.3Ah |
| | 5 hour rate (2080mA) | 10.4Ah |
| | 1 hour rate (8100mA) | 8.1Ah |
| | 1.5 hour rate discharge Cut-off voltage 10.5 V | 5.8A |
| Internal resistance | Fully charged battery (20°C) | Approx. 30mΩ |
| Temperature dependency of capacity (20 hour rate) | 40°C | 102% |
| | 20°C | 100% |
| | 0°C | 85% |
| | -15°C | 65% |
| Self discharge (20°C) | Residual capacity after standing 3 months | 91% |
| | Residual capacity after standing 6 months | 83% |
| | Residual capacity after standing 12 months | 66% |

(Note) The above characteristics data are average values obtained within three charge/discharge cycles, not the minimum values.

For main and standby power supplies.
Trickle Design life: 6 years at 20°C.

Dimensions (mm)

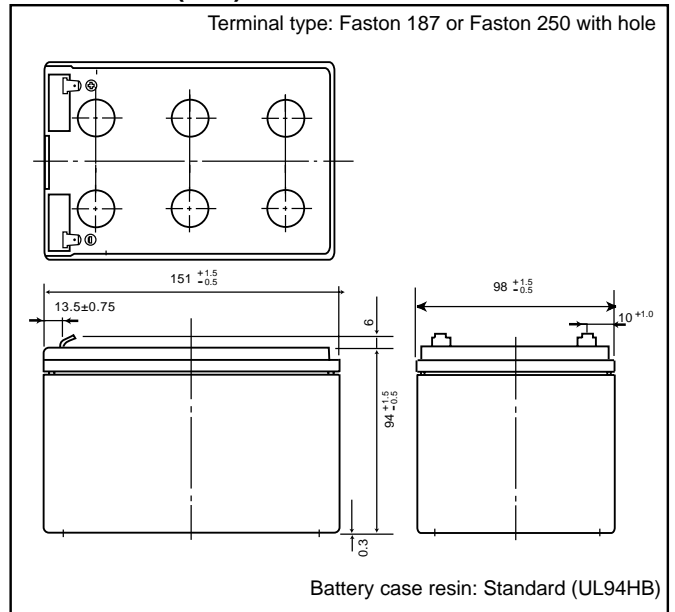

Discharge characteristics (20°C) (Note)

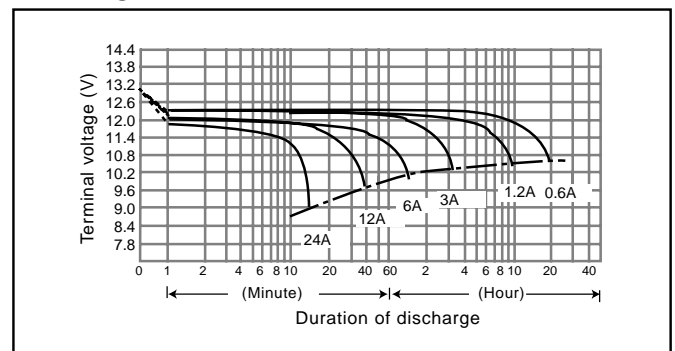

Duration of discharge vs. Discharge current (Note)

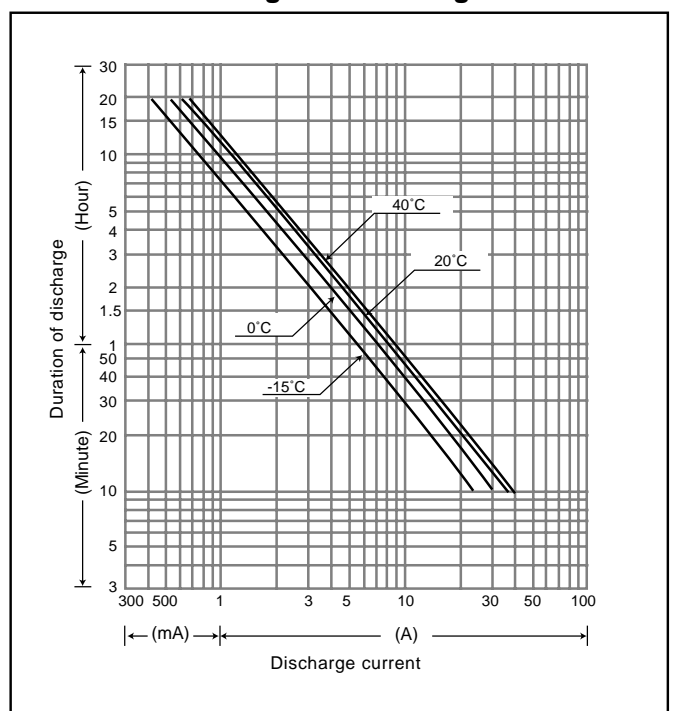

LC-RD1217P/LC-RD1217AP



Labels will vary, see page 68 for example of labels.

(a) The photo and dimensions represent LC-RD1217P.

Specifications

| | | |
|-------------------------------|--------------|--------|
| Nominal voltage | | 12V |
| Rated capacity (20 hour rate) | | 17Ah |
| Dimensions | Length | 181 mm |
| | Width | 76 mm |
| | Height | 167 mm |
| | Total Height | 167 mm |
| Approx. mass | | 6.5 kg |

Characteristics

| | | |
|---|---|--------------|
| Capacity (note) (20°C) | 20 hour rate (850mA) | 17Ah |
| | 10 hour rate (1500mA) | 15Ah |
| | 5 hour rate (2600mA) | 13Ah |
| | 1 hour rate (10000mA) | 10Ah |
| | 1.5 hour rate discharge Cut-off voltage 10.5 V | 7A |
| Internal resistance | Fully charged battery (20°C) | Approx. 12mΩ |
| Temperature dependency of capacity (20 hour rate) | 40°C | 102% |
| | 20°C | 100% |
| | 0°C | 85% |
| | -15°C | 65% |
| Self discharge (20°C) | Residual capacity after standing 3 months | 91% |
| | Residual capacity after standing 6 months | 83% |
| | Residual capacity after standing 12 months | 66% |

(Note) The above characteristics data are average values obtained within three charge/discharge cycles, not the minimum values.

(Note) For cycle use of the battery, please contact us in advance.

For main and standby power supplies.
Trickle Design life: 10 years at 20°C.

Dimensions (mm)

Terminal type: LC-RD1217P: M5 bolt and nut
LC-RD1217AP: M5 threaded post

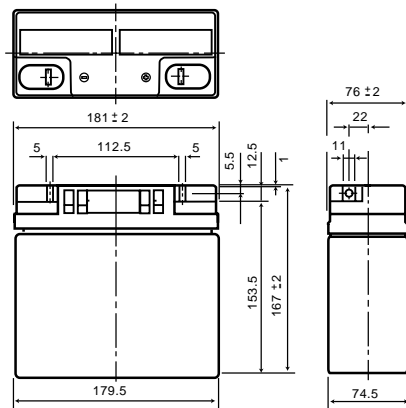

Battery case resin: Standard (UL94HB)
Flame-retardant (UL94V-0)

Discharge characteristics (20°C) (Note)

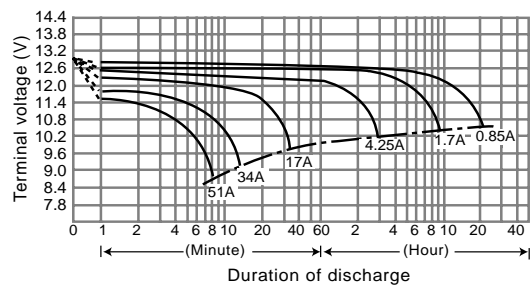

Duration of discharge vs. Discharge current (Note)

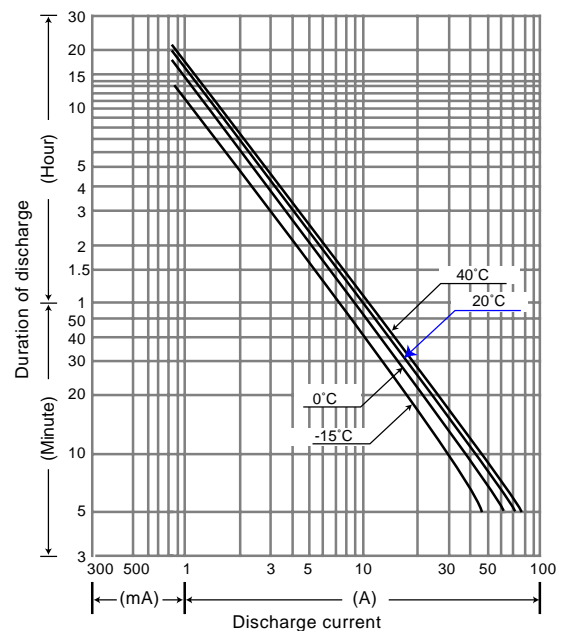

LC-X1220P/LC-X1220AP



Labels will vary, see page 68 for example of labels.

(a) The photo and dimensions represent LC-X1220P

For main and standby power supplies.
Trickle Design life: 10 years at 20°C.

Dimensions (mm)

Terminal type: LC-X1220P: M5 bolt and nut
LC-X1220AP: M5 threaded post

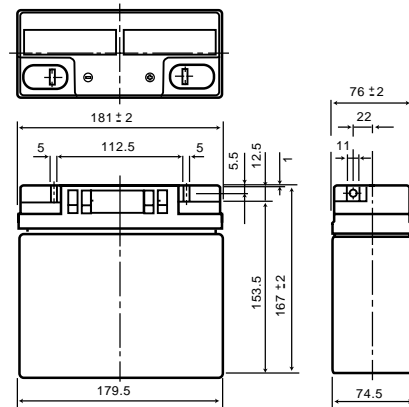

Battery case resin: Standard (UL94HB)

Specifications

| | | |
|---------------------------------|--------------|--------|
| Nominal voltage | | 12V |
| Nominal capacity (20 hour rate) | | 20Ah |
| Dimensions | Length | 181 mm |
| | Width | 76 mm |
| | Height | 167 mm |
| | Total Height | 167 mm |
| Approx. mass | | 6.6 kg |

Characteristics

| | | |
|---|---|--------------|
| Capacity (note) (20°C) | 20 hour rate (1.2A) | 20Ah |
| | 10 hour rate (2.2A) | 18Ah |
| | 5 hour rate (3.8A) | 16Ah |
| | 1 hour rate (14A) | 12Ah |
| | 1.5 hour rate discharge Cut-off voltage 10.5 V | 9.8A |
| Internal resistance | Fully charged battery (20°C) | Approx. 11mΩ |
| Temperature dependency of capacity (20 hour rate) | 40°C | 102% |
| | 20°C | 100% |
| | 0°C | 85% |
| Self discharge (20°C) | -15°C | 65% |
| | Residual capacity after standing 3 months | 91% |
| | Residual capacity after standing 6 months | 83% |
| | Residual capacity after standing 12 months | 66% |

(Note) The above characteristics data are average values obtained within three charge/discharge cycles, not the minimum values.

(Note) For cycle use of the battery, please contact us in advance.

Discharge characteristics (20°C) (Note)

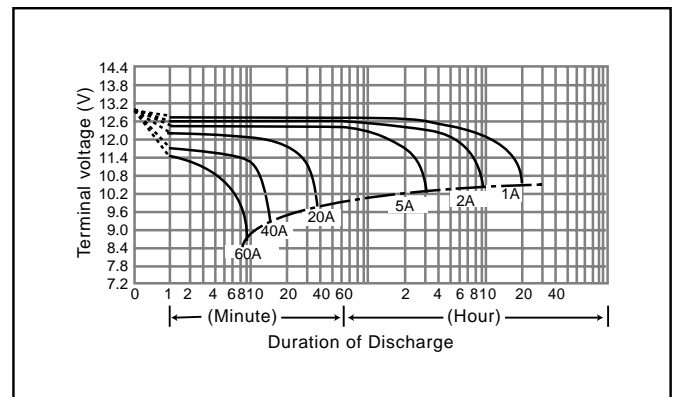

Duration of discharge vs. Discharge current (Note)

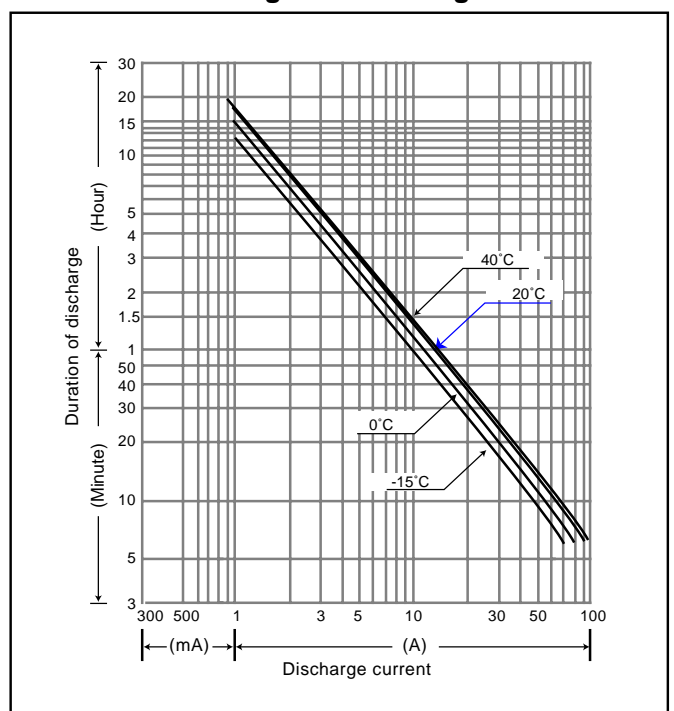

LC-X1224AP/LC-X1224P



Labels will vary, see page 68 for example of labels.

(a) The photo and dimensions represent LC-X1224AP

Specifications

| | | |
|-------------------------------|--------------|---|
| Nominal voltage | | 12V |
| Rated capacity (20 hour rate) | | 24Ah |
| Dimensions | Length | 165 mm |
| | Width | 125 mm |
| | Height | 175 mm |
| | Total Height | LC-X1224AP:175 mm LC-X1224P:179.5 mm |
| Approx. mass | | 9 kg |

Characteristics

| | | |
|---|---|--------------|
| Capacity ^(note) (20°C) | 20 hour rate (1.2A) | 24Ah |
| | 10 hour rate (2.2A) | 22Ah |
| | 5 hour rate (3.8A) | 19Ah |
| | 1 hour rate (14A) | 14Ah |
| | 1.5 hour rate discharge Cut-off voltage 10.5 V | 9.8A |
| Internal resistance | Fully charged battery (20°C) | Approx. 11mΩ |
| Temperature dependency of capacity (20 hour rate) | 40°C | 102% |
| | 20°C | 100% |
| | 0°C | 85% |
| | -15°C | 65% |
| Self discharge (20°C) | Residual capacity after standing 3 months | 91% |
| | Residual capacity after standing 6 months | 83% |
| | Residual capacity after standing 12 months | 66% |

(Note) The above characteristics data are average values obtained within three charge/discharge cycles, not the minimum values.

For standby power supplies.
Trickle Design life: 10 years at 20°C.

Dimensions (mm)

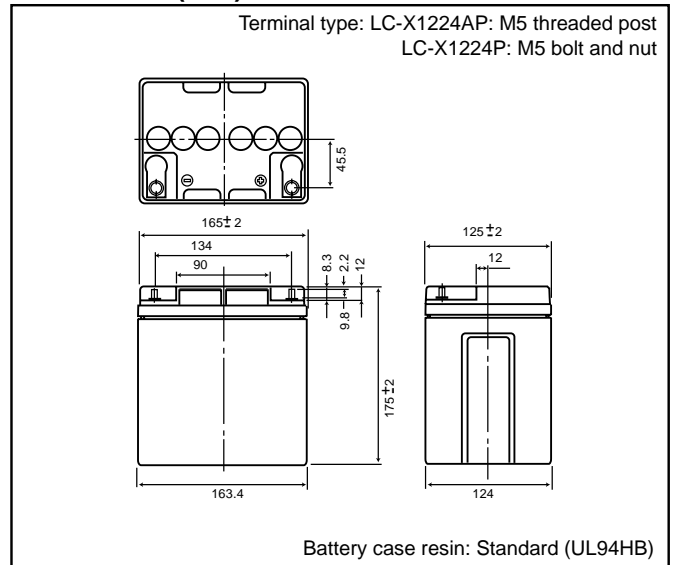

Discharge characteristics (20°C) (Note)

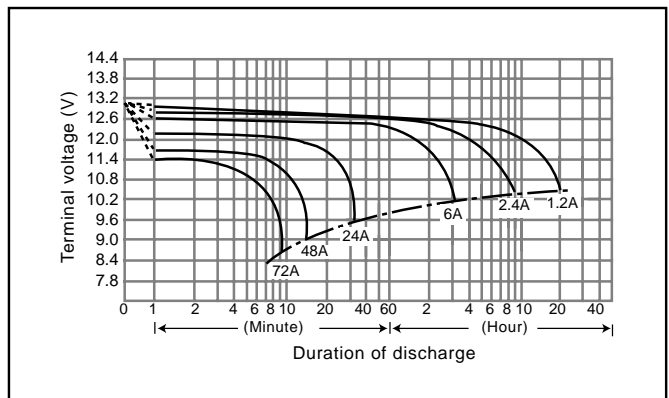

Duration of discharge vs. Discharge current (Note)

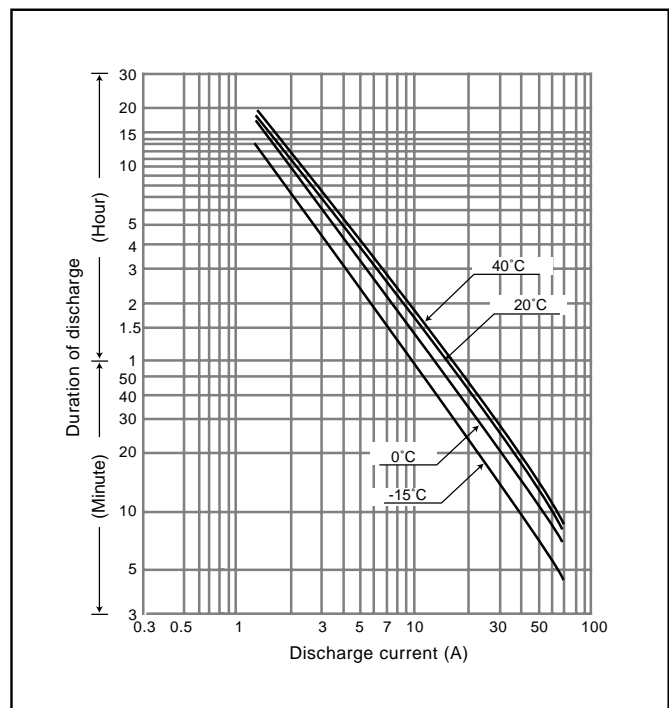

LC-X1228AP/LC-X1228P



(a) The photo and dimensions represent LC-X1228AP

Specifications

| | | |
|-------------------------------|--------------|---|
| Nominal voltage | | 12V |
| Rated capacity (20 hour rate) | | 28Ah |
| Dimensions | Length | 165 mm |
| | Width | 125 mm |
| | Height | 175 mm |
| | Total Height | LC-X1228AP: 175 mm LC-X1228P: 179.5 mm |
| Approx. mass | | 11 kg |

Characteristics

| | | |
|--|---|-------------|
| Capacity (note) (20°C) | 20 hour rate (1.4A) | 28.0Ah |
| | 10 hour rate (2.65A) | 26.5Ah |
| Internal resistance | 5 hour rate (5A) | 25.0Ah |
| | 1 hour rate (21A) | 21.0Ah |
| | 1.5 hour rate discharge Cut-off voltage 10.5 V | 9.8A |
| Temperature dependency of capacity (20 hour rate) | Fully charged battery (20°C) | Approx. 8mΩ |
| Self discharge (20°C) | 40°C | 102% |
| | 20°C | 100% |
| | 0°C | 85% |
| | -15°C | 65% |
| Duration of discharge vs. Discharge current (Note) | Residual capacity after standing 3 months | 91% |
| | Residual capacity after standing 6 months | 83% |
| | Residual capacity after standing 12 months | 66% |

(Note) The above characteristics data are average values obtained within three charge/discharge cycles, not the minimum values.

For standby power supplies.
Trickle Design life: 10 years at 20°C.

Dimensions (mm)

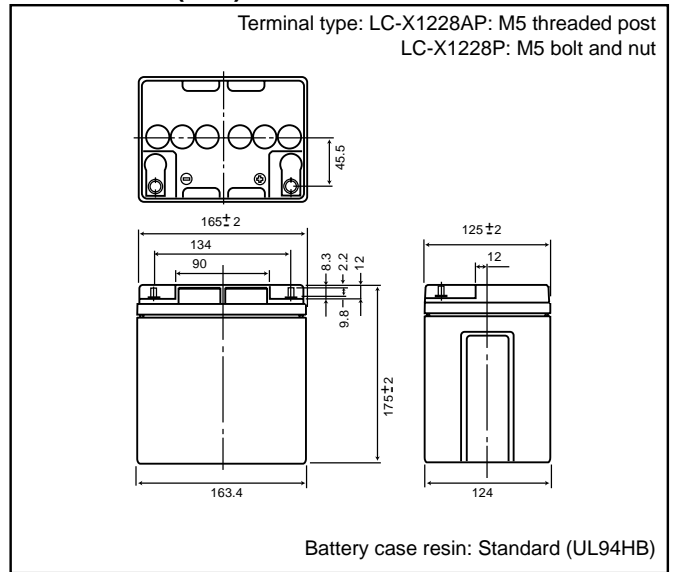

Discharge characteristics (20°C) (Note)

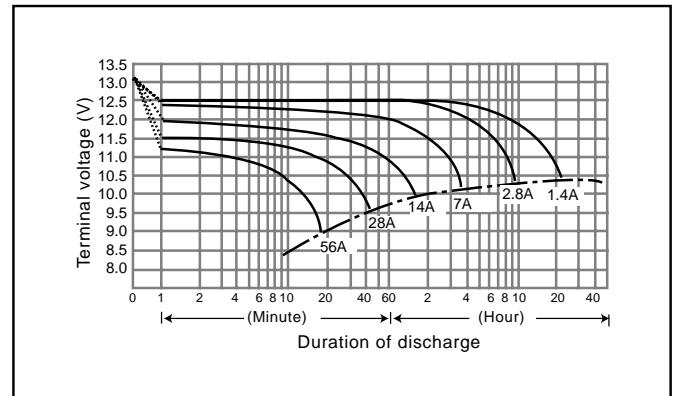

Duration of discharge vs. Discharge current (Note)

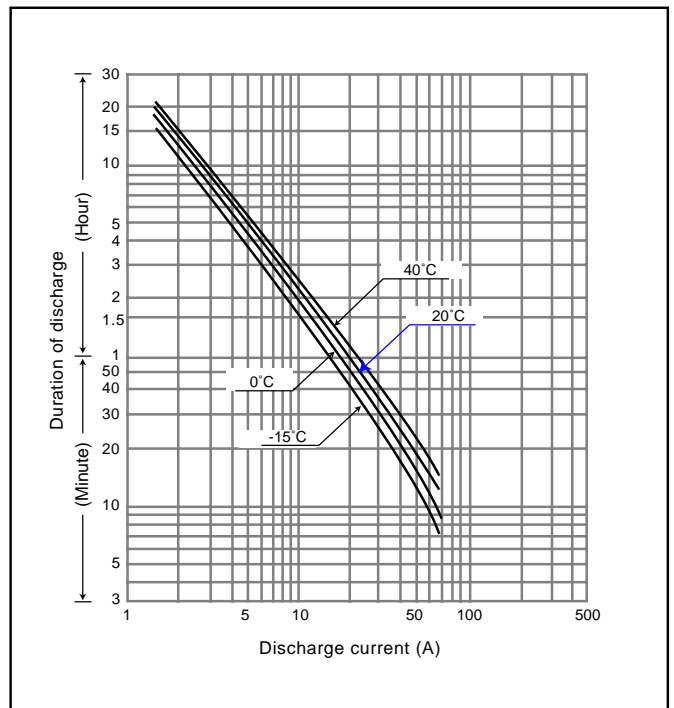

LC-XC1228AP/LC-XC1228P

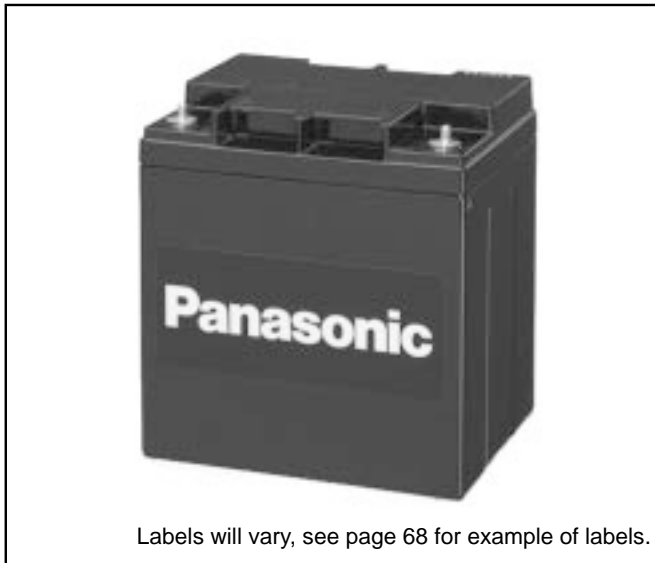

Labels will vary, see page 68 for example of labels.

(a) The photo and dimensions represent LC-XC1228AP

For main power supplies.
Cycle long life type.

Dimensions (mm)

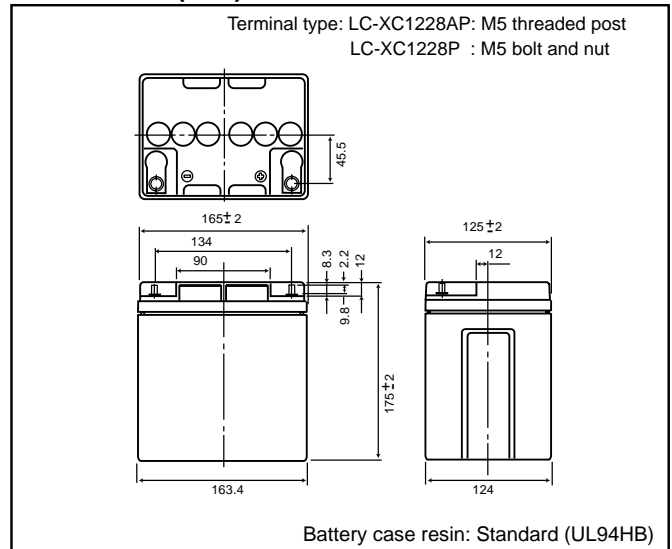

Specifications

| | | |
|-------------------------------|--------------|--|
| Nominal voltage | | 12V |
| Rated capacity (20 hour rate) | | 28Ah |
| Dimensions | Length | 165 mm |
| | Width | 125 mm |
| | Height | 175 mm |
| | Total Height | LC-XC1228AP: 175 mm LC-XC1228P : 179.5 mm |
| Approx. mass | | 11 kg |

Discharge characteristics (20°C) (Note)

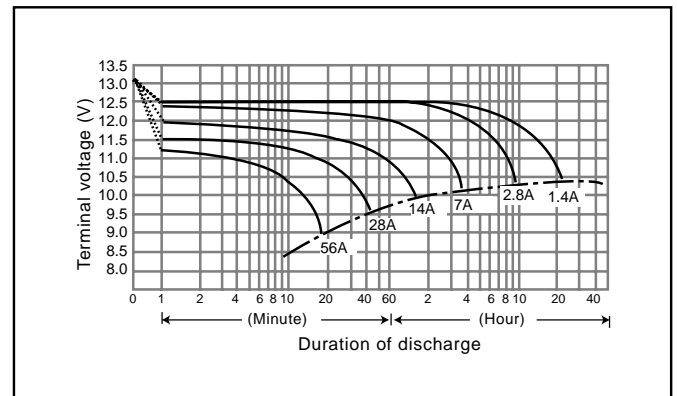

Characteristics

| | | |
|---|---|--------------|
| Capacity (note) (20°C) | 20 hour rate (1.4A) | 28.0Ah |
| | 10 hour rate (2.65A) | 26.5Ah |
| | 5 hour rate (5A) | 25.0Ah |
| | 1 hour rate (21A) | 21.0Ah |
| | 1.5 hour rate discharge Cut-off voltage 10.5 V | 9.8A |
| Internal resistance | Fully charged battery (20°C) | Approx. 10mΩ |
| Temperature dependency of capacity (20 hour rate) | 40°C | 102% |
| | 20°C | 100% |
| | 0°C | 85% |
| Self discharge (20°C) | Residual capacity after standing 3 months | 91% |
| | Residual capacity after standing 6 months | 83% |
| | Residual capacity after standing 12 months | 66% |

(Note) The above characteristics data are average values obtained within three charge/discharge cycles, not the minimum values.

Duration of discharge vs. Discharge current (Note)

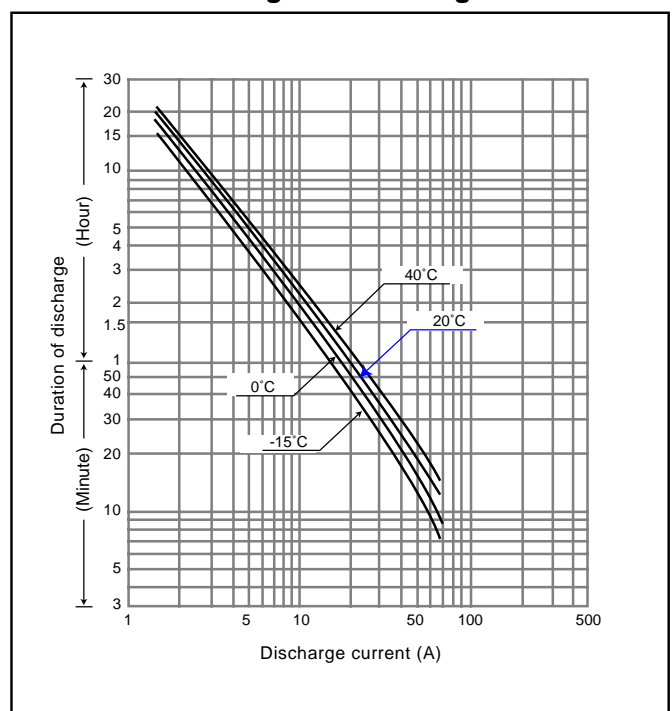

LC-LA1233P/LC-VA1233P



Specifications

| | | |
|-------------------------------|--------------|----------|
| Nominal voltage | | 12V |
| Rated capacity (20 hour rate) | | 33Ah |
| Dimensions | Length | 195.6 mm |
| | Width | 130 mm |
| | Height | 155 mm |
| | Total Height | 180 mm |
| Approx. mass | | 12 kg |

Characteristics

| | | |
|--|---|-------------|
| Capacity (note) (20°C) | 20 hour rate (1.65A) | 33Ah |
| | 10 hour rate (3A) | 30Ah |
| | 5 hour rate (5.4A) | 27Ah |
| | 1 hour rate (20A) | 20Ah |
| | 1.5 hour rate discharge Cut-off voltage 10.5 V | 13.4A |
| Internal resistance | Fully charged battery (20°C) | Approx. 7mΩ |
| Temperature dependency of capacity (20 hour rate) | 40°C | 102% |
| | 20°C | 100% |
| | 0°C | 85% |
| | -15°C | 65% |
| Self discharge (20°C) | Residual capacity after standing 3 months | 91% |
| | Residual capacity after standing 6 months | 83% |
| | Residual capacity after standing 12 months | 66% |

(Note) The above characteristics data are average values obtained within three charge/discharge cycles, not the minimum values.

(Note) For cycle use of the battery, please consult us in advance.

For main and standby power supplies.
Trickle Design life: 6 years at 20°C.

Dimensions (mm)

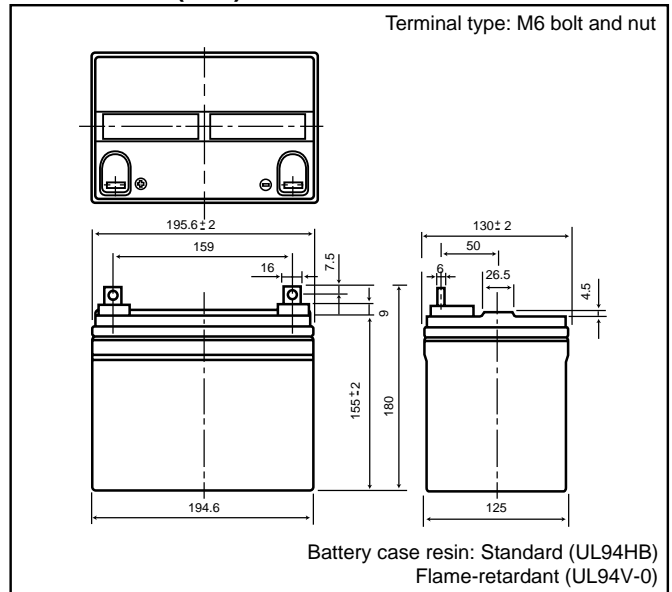

Discharge characteristics (20°C) (Note)

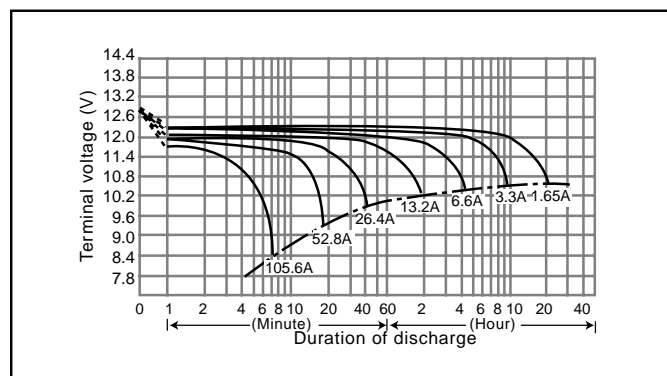

Duration of discharge vs. Discharge current (Note)

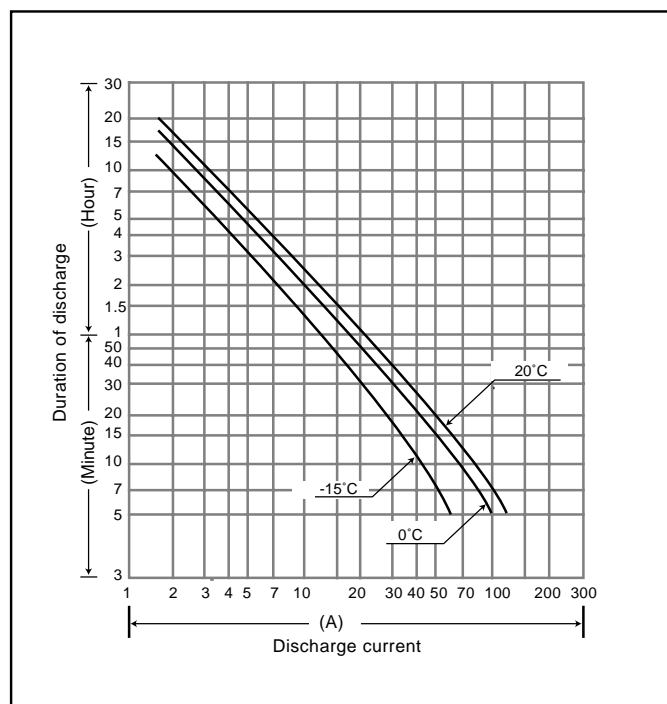

LC-X1238AP/LC-X1238P



Labels will vary, see page 68 for example of labels.

(a) The photo and dimensions represent LC-X1238AP

Specifications

| | | |
|-------------------------------|--------------|---|
| Nominal voltage | | 12V |
| Rated capacity (20 hour rate) | | 38Ah |
| Dimensions | Length | 197 mm |
| | Width | 165 mm |
| | Height | 175 mm |
| | Total Height | LC-X1238AP: 175 mm LC-X1238P: 180 mm |
| Approx. mass | | 13 kg |

Characteristics

| | | |
|---|---|-------------|
| Capacity (note) (20°C) | 20 hour rate (1.9A) | 38.0Ah |
| | 10 hour rate (3.5A) | 35.0Ah |
| Internal resistance | 5 hour rate (6.3A) | 31.5Ah |
| | 1 hour rate (22.5A) | 22.5Ah |
| | 1.5 hour rate discharge Cut-off voltage 10.5 V | 15.5A |
| Temperature dependency of capacity (20 hour rate) | Fully charged battery (20°C) | Approx. 8mΩ |
| | 40°C | 102% |
| | 20°C | 100% |
| | 0°C | 85% |
| Self discharge (20°C) | -15°C | 65% |
| | Residual capacity after standing 3 months | 91% |
| | Residual capacity after standing 6 months | 83% |
| | Residual capacity after standing 12 months | 66% |

(Note) The above characteristics data are average values obtained within three charge/discharge cycles, not the minimum values.

For standby power supplies.
Trickle Design life: 10 years at 20°C.

Dimensions (mm)

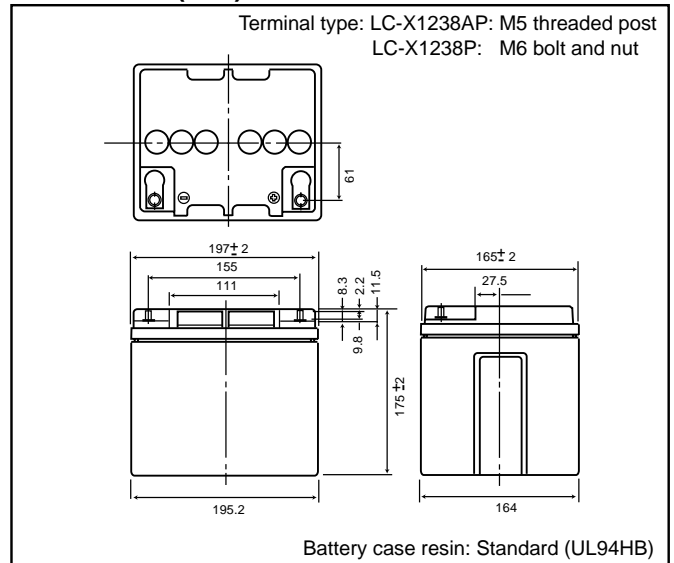

Discharge characteristics (20°C) (Note)

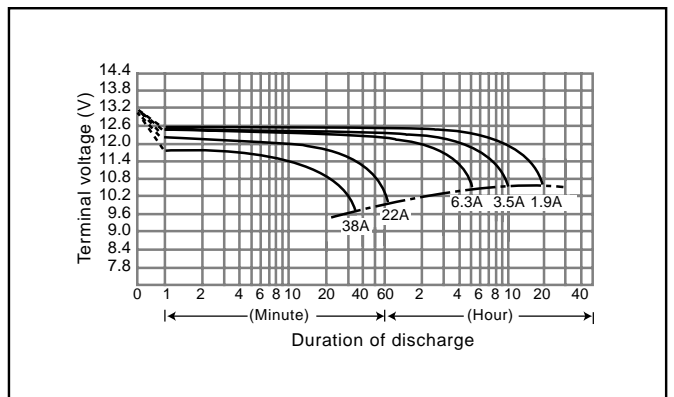

Duration of discharge vs. Discharge current (Note)

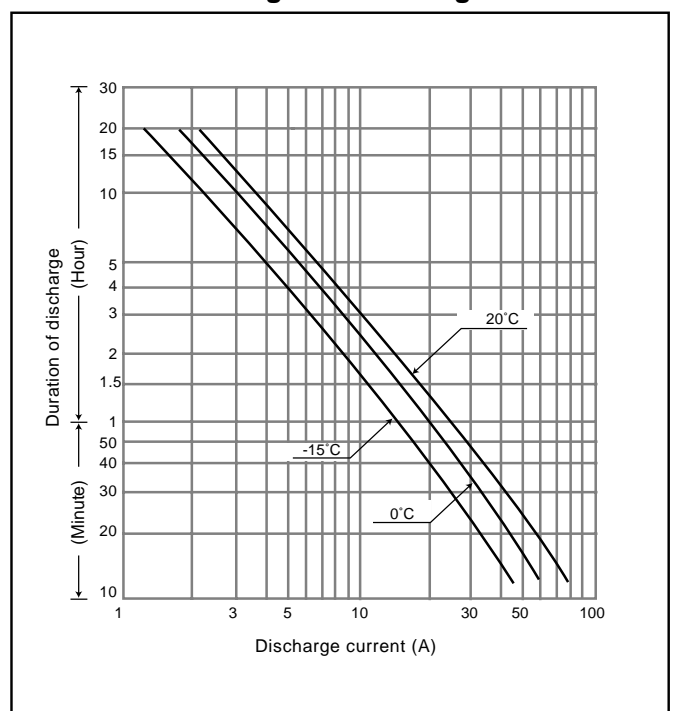

LC-XC1238-AP/LC-XC1238-P



Labels will vary, see page 68 for example of labels.

(a) The photo and dimensions represent LC-X1238AP

For main power supplies.
Cycle long life type.

Dimensions (mm)

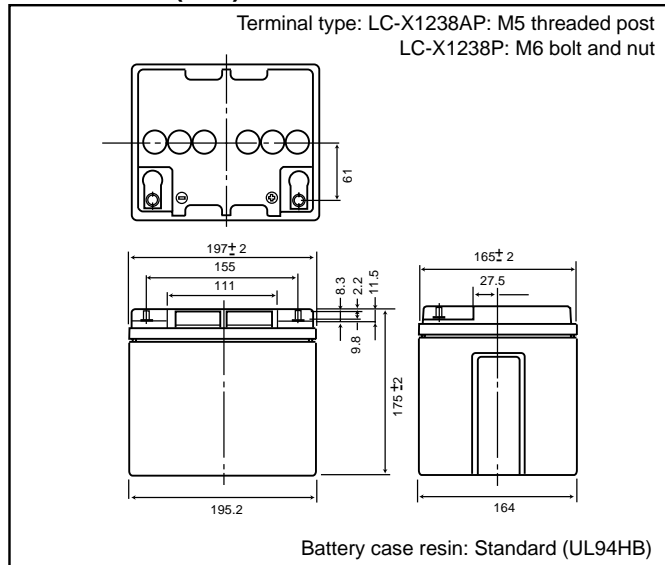

Specifications

| | | |
|-------------------------------|--------------|--|
| Nominal voltage | | 12V |
| Rated capacity (20 hour rate) | | 38Ah |
| Dimensions | Length | 197 mm |
| | Width | 165 mm |
| | Height | 175 mm |
| | Total Height | LC-XC1238AP: 175 mm LC-XC1238P : 179.5 mm |
| Approx. mass | | 15 kg |

Discharge characteristics (20°C) (Note)

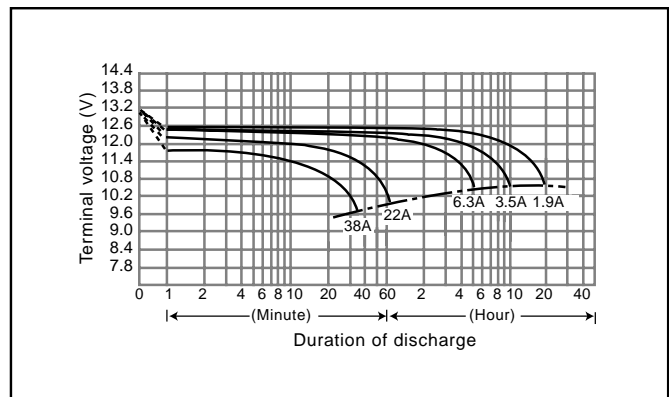

Characteristics

| | | |
|---|---|------------|
| Capacity (note) (20°C) | 20 hour rate (1.9A) | 38.0Ah |
| | 10 hour rate (3.5A) | 35.0Ah |
| Internal resistance | 5 hour rate (6.3A) | 31.5Ah |
| | 1 hour rate (22.5A) | 22.5Ah |
| | 1.5 hour rate discharge Cut-off voltage 10.5 V | 15.5A |
| Temperature dependency of capacity (20 hour rate) | Fully charged battery (20°C) | Approx.9mΩ |
| | 40°C | 102% |
| | 20°C | 100% |
| | 0°C | 85% |
| Self discharge (20°C) | -15°C | 65% |
| | Residual capacity after standing 3 months | 91% |
| | Residual capacity after standing 6 months | 83% |
| | Residual capacity after standing 12 months | 66% |

(Note) The above characteristics data are average values obtained within three charge/discharge cycles, not the minimum values.

Duration of discharge vs. Discharge current (Note)

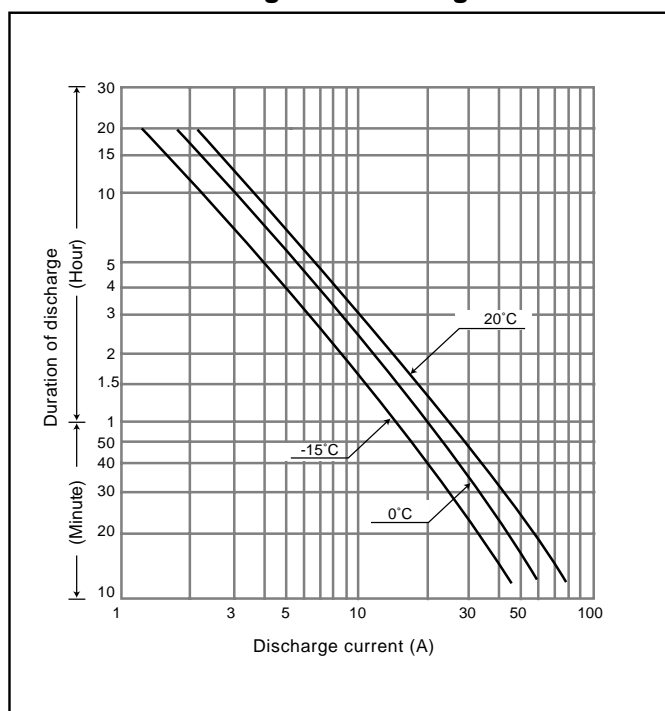

LC-X1242AP/LC-X1242P



Labels will vary, see page 68 for example of labels.

(a) The photo and dimensions represent LC-X1242AP

For standby power supplies.
Trickle Design life: 10 years at 20°C

Dimensions (mm)

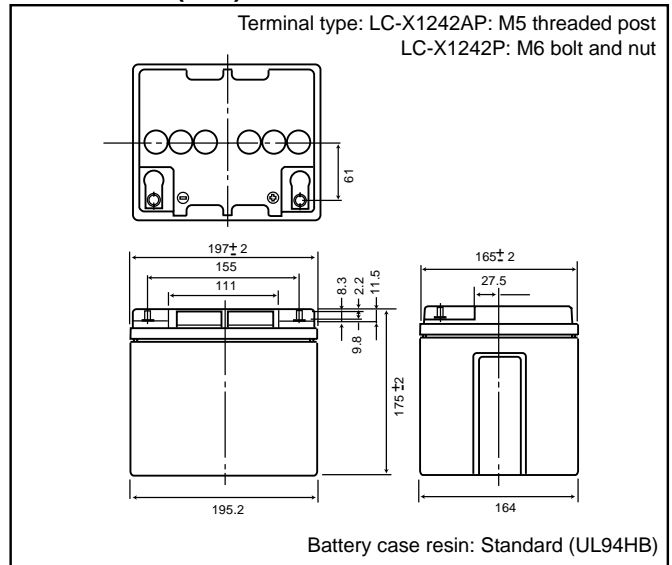

Specifications

| | | |
|-------------------------------|--------|---|
| Nominal voltage | | 12V |
| Rated capacity (20 hour rate) | | 42Ah |
| Dimensions | Length | 197 mm |
| | Width | 165 mm |
| | Height | 175 mm |
| Total Height | | LC-X1242AP: 175 mm LC-X1242P: 180 mm |
| Approx. mass | | 16 kg |

Discharge characteristics (20°C) (Note)

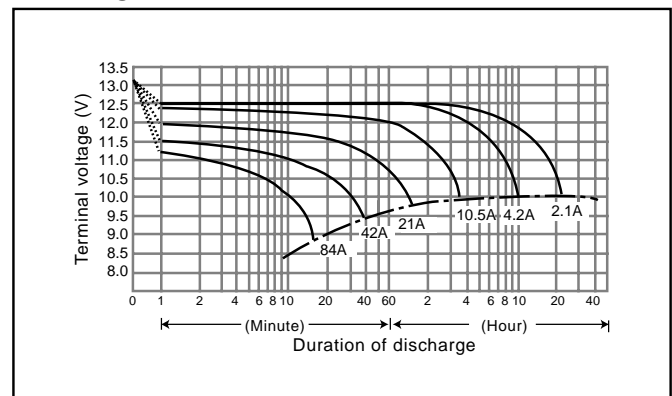

Characteristics

| | | |
|---|---|-------------|
| Capacity (note) (20°C) | 20 hour rate (2.1A) | 42Ah |
| | 10 hour rate (4A) | 40Ah |
| | 5 hour rate (7.4A) | 37Ah |
| | 1 hour rate (26A) | 26Ah |
| 1.5 hour rate discharge Cut-off voltage 10.5 V | | 15.5A |
| Internal resistance | Fully charged battery (20°C) | Approx. 8mΩ |
| Temperature dependency of capacity (20 hour rate) | 40°C | 102% |
| | 20°C | 100% |
| | 0°C | 85% |
| | -15°C | 65% |
| Self discharge (20°C) | Residual capacity after standing 3 months | 91% |
| | Residual capacity after standing 6 months | 83% |
| | Residual capacity after standing 12 months | 66% |

(Note) The above characteristics data are average values obtained within three charge/discharge cycles, not the minimum values.

Duration of discharge vs. Discharge current (Note)

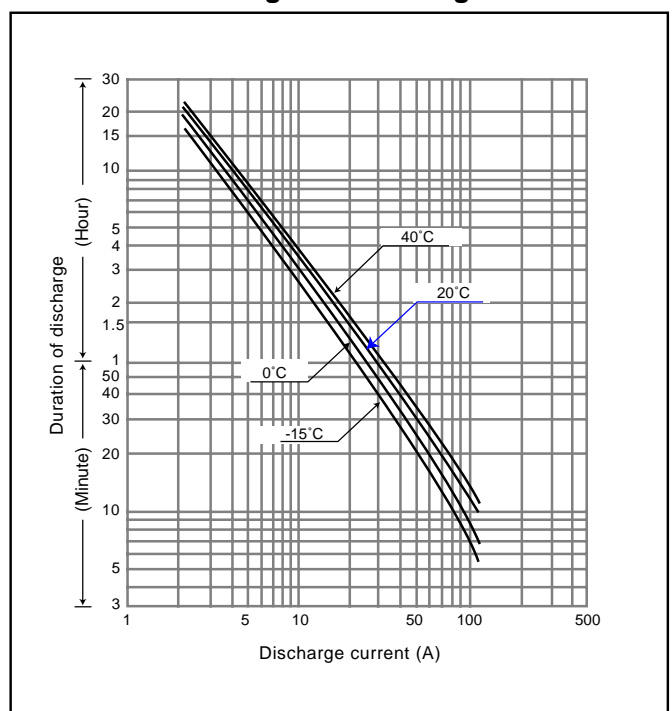

LC-X1265P



Labels will vary, see page 68 for example of labels.

Specifications

| | | |
|-------------------------------|--------------|--------|
| Nominal voltage | | 12V |
| Rated capacity (20 hour rate) | | 65Ah |
| Dimensions | Length | 350 mm |
| | Width | 166 mm |
| | Height | 175 mm |
| | Total Height | 175 mm |
| Approx. mass | | 20 kg |

Characteristics

| | | |
|--|---|-------------|
| Capacity ^(note) (20°C) | 20 hour rate (3.25A) | 65Ah |
| | 10 hour rate (5.9A) | 59Ah |
| | 5 hour rate (10.6A) | 53Ah |
| | 1 hour rate (40A) | 40Ah |
| | 1.5 hour rate discharge Cut-off voltage 10.5 V | 26A |
| Internal resistance | Fully charged battery (20°C) | Approx. 7mΩ |
| Temperature dependency of capacity (20 hour rate) | 40°C | 102% |
| | 20°C | 100% |
| | 0°C | 85% |
| | -15°C | 65% |
| Self discharge (20°C) | Residual capacity after standing 3 months | 91% |
| | Residual capacity after standing 6 months | 83% |
| | Residual capacity after standing 12 months | 66% |

(Note) The above characteristics data are average values obtained within three charge/discharge cycles, not the minimum values.

For standby power supplies.
Trickle Design life: 10 years at 20°C.

Dimensions (mm)

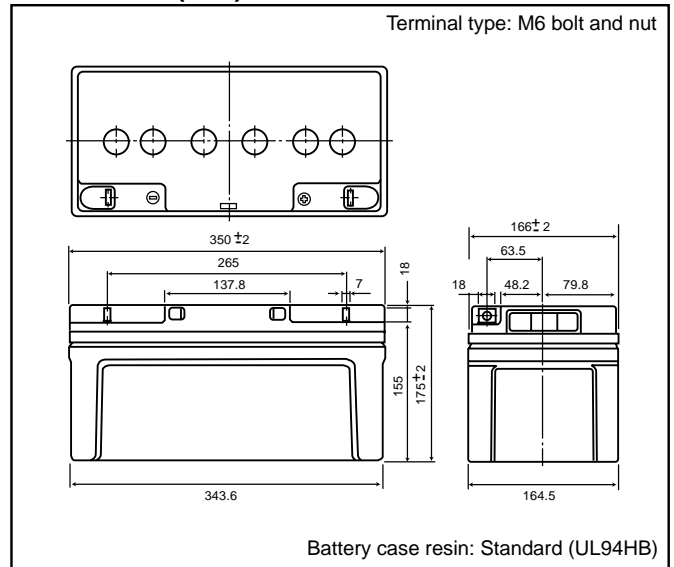

Discharge characteristics (20°C) (Note)

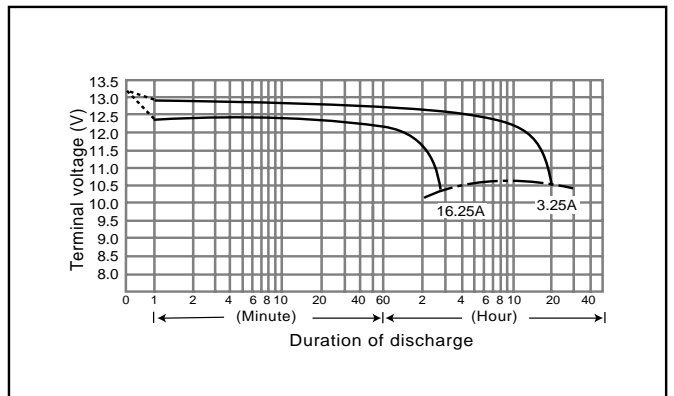

Duration of discharge vs. Discharge current (Note)

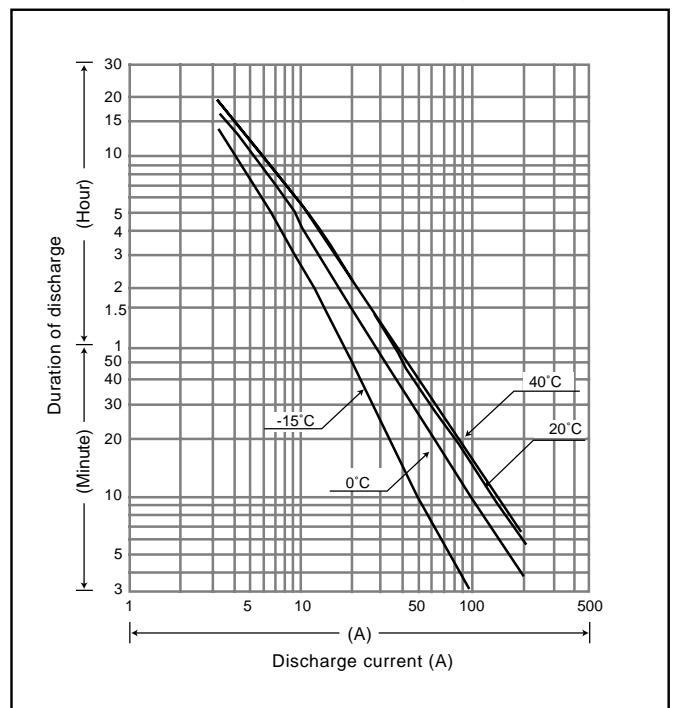

LC-XB12100P



For standby power supplies.

Dimensions (mm)

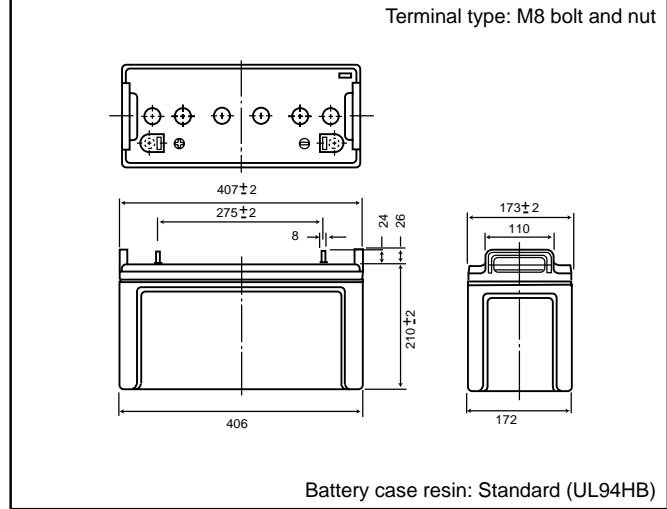

Specifications

| | | |
|-------------------------------|--------------|--------|
| Nominal voltage | | 12V |
| Rated capacity (20 hour rate) | | 100Ah |
| Dimensions | Length | 407 mm |
| | Width | 173 mm |
| | Height | 210 mm |
| | Total Height | 236 mm |
| Approx. mass | | 37 kg |

Discharge characteristics (20°C) (Note)

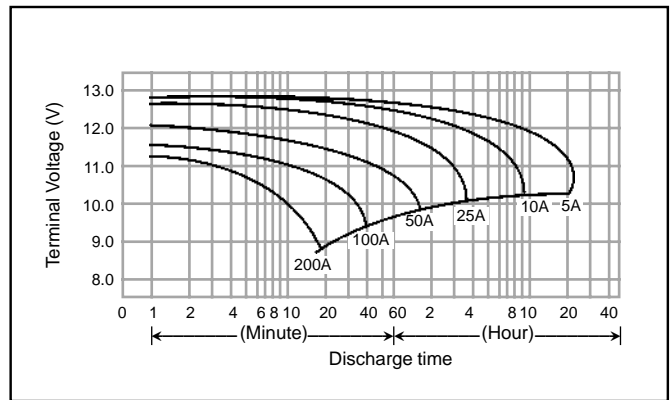

Characteristics

| | | |
|--|---|---------------|
| Capacity (note) (20°C) | 20 hour rate (5A) | 100Ah |
| | 10 hour rate (9.8A) | 98Ah |
| Internal resistance | 5 hour rate (18A) | 90Ah |
| | 1 hour rate (75A) | 75Ah |
| | 1.5 hour rate discharge Cut-off voltage 10.5 V | 50A |
| Temperature dependency of capacity (20 hour rate) | Fully charged battery (20°C) | Approx. 4.5mΩ |
| Self discharge (20°C) | 40°C | 102% |
| | 20°C | 100% |
| | 0°C | 85% |
| | -15°C | 65% |
| Duration of discharge vs. Discharge current (Note) | Residual capacity after standing 3 months | 91% |
| | Residual capacity after standing 6 months | 83% |
| | Residual capacity after standing 12 months | 66% |

(Note) The above characteristics data are average values obtained within three charge/discharge cycles, not the minimum values.

Duration of discharge vs. Discharge current (Note)

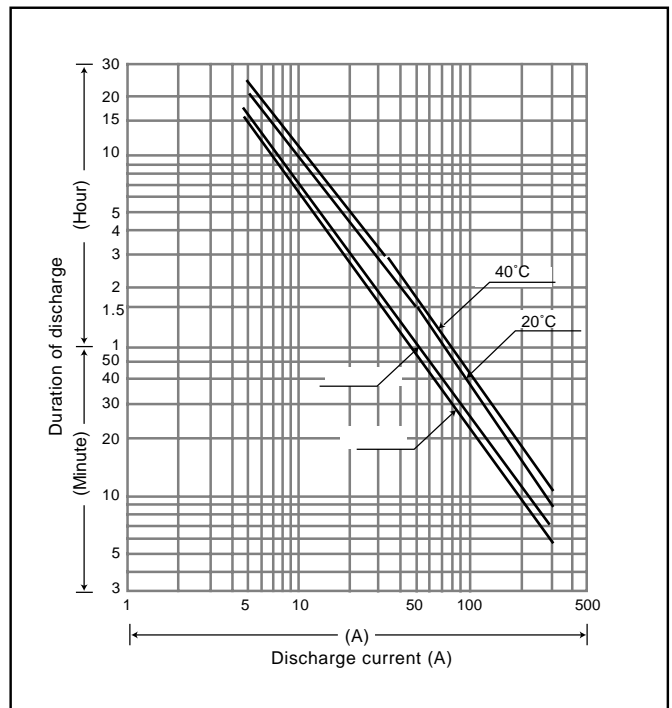

UP-RW1220P1



For standby power supplies.
Trickle Design life: 6 years at 20°C

Dimensions (mm)

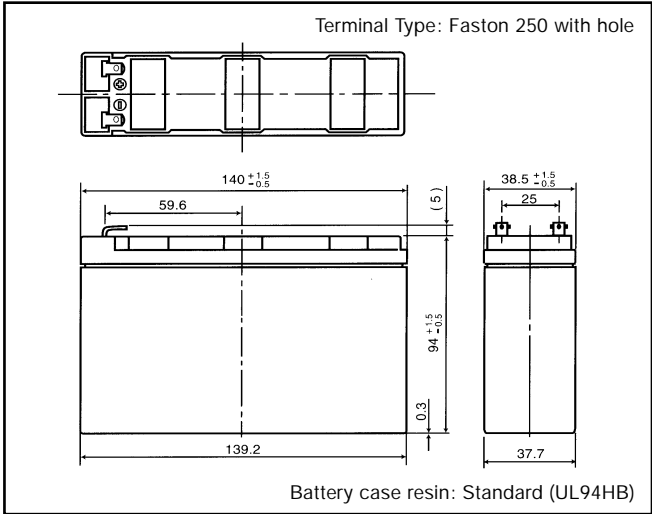

Specifications

| | | |
|-----------------------------------|--------------|-------------|
| Normal voltage | 12V | |
| Nominal capacity (10 minute rate) | 20W/2V | |
| Dimensions | Length | 140.0 mm |
| | Width | 38.5 mm |
| | Height | 94.0 mm |
| | Total Height | max. 100 mm |
| Approx. mass | 1.35 kg | |

Discharge characteristics (20°C) (Note)

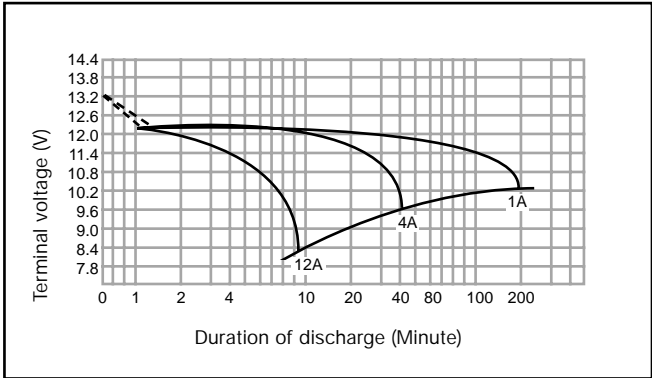

Characteristics

| | | |
|---|--|--------------|
| Capacity (note) (20°C) (9.6V cutoff) | 30 minute rate | 155W |
| | 15 minute rate | 86W |
| | 10 minute rate | 114W |
| | 5 minute rate | 171W |
| Internal resistance | Fully charged battery (20°C) | Approx. 44mΩ |
| Temperature dependency of capacity (10 hour rate) | 40°C | 102% |
| | 20°C | 100% |
| | 0°C | 82% |
| | 15°C | 65% |
| Self discharge (20°C) | Residual capacity after standing 3 months | 91% |
| | Residual capacity after standing 6 months | 83% |
| | Residual capacity after standing 12 months | 66% |

Duration of discharge vs. Discharge current (Note)

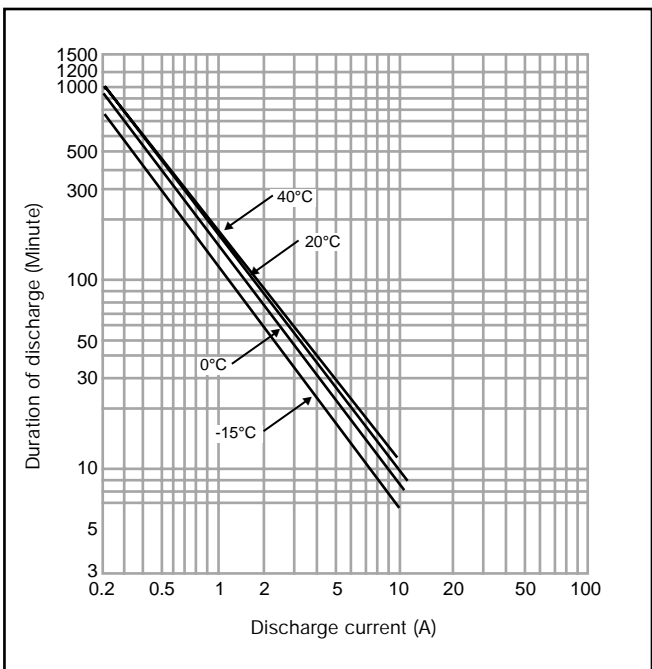

Watt Table

| Cutoff | Discharge Runtime at 20°C (unit: watt) | | | | | | | |
|--------|--|-------|-------|--------|--------|--------|--------|--|
| | 3 min | 5 min | 7 min | 10 min | 15 min | 20 min | 30 min | |
| 9.6V | 225 | 171 | 142 | 114 | 86 | 72 | 55 | |
| 10.2V | 206 | 158 | 128 | 107 | 82 | 70 | 50 | |
| 10.8V | 168 | 130 | 109 | 96 | 77 | 64 | 45 | |

(Note) The above characteristics data are average values obtained within three charge/discharge cycles, not the minimum values.

(Note) This battery is designed for high-rate discharge, therefore we do not specify 20-hour-rate discharge capacity.

(Note) When specific conditions are satisfied, this battery can be used for main power supplies. Please consult Panasonic.

UP-RWA1232P1



For standby power supplies.
Trickle Design life 6 years at 20°C

Dimensions (mm)

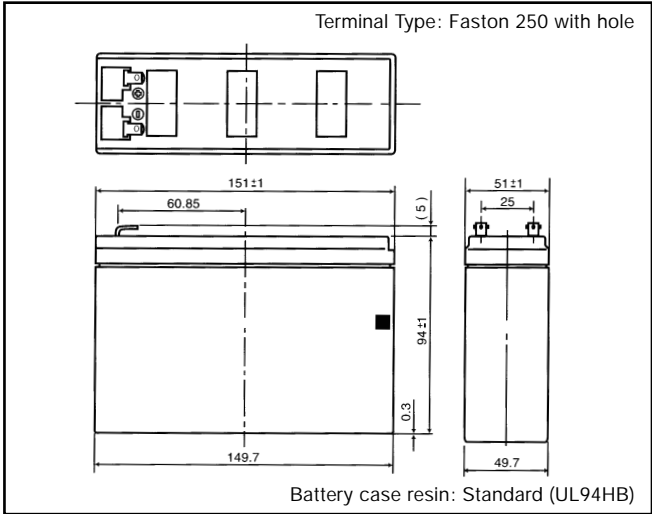

Specifications

| | | |
|-----------------------------------|--------------|-------------|
| Normal voltage | 12V | |
| Nominal capacity (10 minute rate) | 32W/2V | |
| Dimensions | Length | 151.0 mm |
| | Width | 51.0 mm |
| | Height | 94.0 mm |
| | Total Height | max. 100 mm |
| Approx. mass | 2.0 kg | |

Discharge characteristics (20°C) (Note)

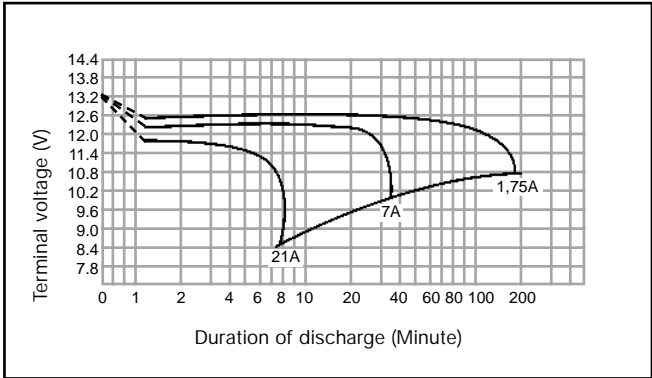

Characteristics

| | | |
|---|--|--------------|
| Capacity (note) (20°C) (9.6V cutoff) | 30 minute rate | 94W |
| | 15 minute rate | 149W |
| | 10 minute rate | 182W |
| | 5 minute rate | 294W |
| Internal resistance | Fully charged battery (20°C) | Approx. 33mΩ |
| Temperature dependency of capacity (10 hour rate) | 40°C | 102% |
| | 20°C | 100% |
| | 0°C | 85% |
| | 15°C | 65% |
| Self discharge (20°C) | Residual capacity after standing 3 months | 91% |
| | Residual capacity after standing 6 months | 83% |
| | Residual capacity after standing 12 months | 66% |

Duration of discharge vs. Discharge current (Note)

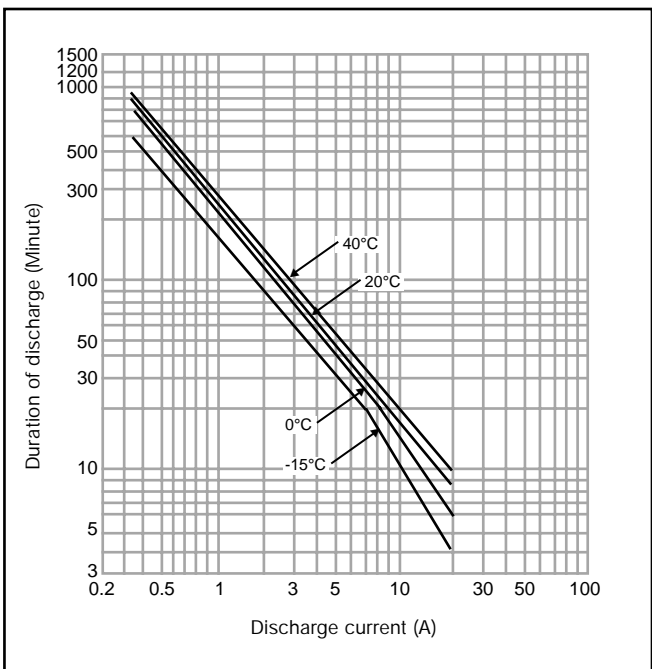

Watt Table

| Cutoff | Discharge Runtime at 20°C (unit: watt) | | | | | | |
|--------|--|-------|-------|--------|--------|--------|--------|
| | 3 min | 5 min | 7 min | 10 min | 15 min | 20 min | 30 min |
| 9.6V | 389 | 294 | 242 | 182 | 149 | 124 | 94 |
| 10.2V | 342 | 266 | 211 | 172 | 134 | 116 | 90 |
| 10.8V | 279 | 218 | 180 | 155 | 123 | 106 | 83 |

(Note) The above characteristics data are average values obtained within three charge/discharge cycles, not the minimum values.

(Note) This battery is designed for high-rate discharge, therefore we do not specify 20-hour-rate discharge capacity.

(Note) When specific conditions are satisfied, this battery can be used for main power supplies. Please consult Panasonic.

UP-RWA1232P1



Labels will vary, see page 68 for example of labels.

For standby power supplies.
Trickle Design life 6 years at 20°C

Dimensions (mm)

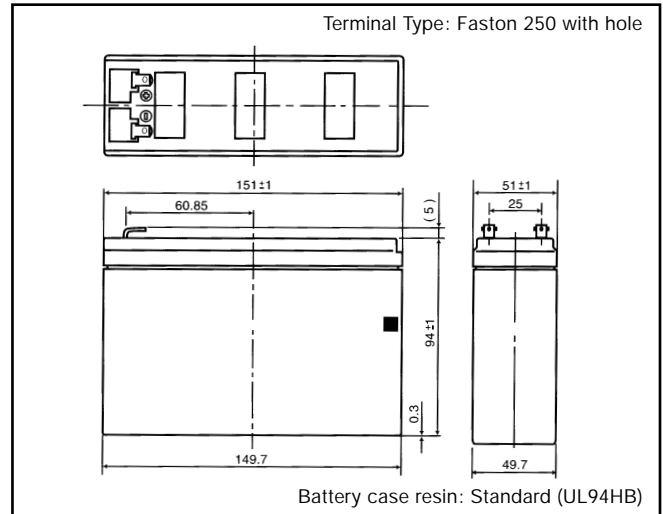

Specifications

| | | |
|-----------------------------------|--------------|-------------|
| Normal voltage | 12V | |
| Nominal capacity (10 minute rate) | 32W/2V | |
| Dimensions | Length | 151.0 mm |
| | Width | 51.0 mm |
| | Height | 94.0 mm |
| | Total Height | max. 100 mm |
| Approx. mass | 2.0 kg | |

Characteristics

| | | |
|---|--|--------------|
| Capacity (note) (20°C) (9.6V cutoff) | 30 minute rate | 94W |
| | 15 minute rate | 149W |
| | 10 minute rate | 182W |
| | 5 minute rate | 294W |
| Internal resistance | Fully charged battery (20°C) | Approx. 33mΩ |
| Temperature dependency of capacity (10 hour rate) | 40°C | 102% |
| | 20°C | 100% |
| | 0°C | 85% |
| | 15°C | 65% |
| Self discharge (20°C) | Residual capacity after standing 3 months | 91% |
| | Residual capacity after standing 6 months | 83% |
| | Residual capacity after standing 12 months | 66% |

Watt Table

| Cutoff | Discharge Runtime at 20°C (unit: watt) | | | | | | | |
|--------|--|-------|-------|--------|--------|--------|--------|--|
| | 3 min | 5 min | 7 min | 10 min | 15 min | 20 min | 30 min | |
| 9.6V | 389 | 294 | 242 | 182 | 149 | 124 | 94 | |
| 10.2V | 342 | 266 | 211 | 172 | 134 | 116 | 90 | |
| 10.8V | 279 | 218 | 180 | 155 | 123 | 106 | 83 | |

(Note) The above characteristics data are average values obtained within three charge/discharge cycles, not the minimum values.

(Note) This battery is designed for high-rate discharge, therefore we do not specify 20-hour-rate discharge capacity.

(Note) When specific conditions are satisfied, this battery can be used for main power supplies. Please consult Panasonic.

Discharge characteristics (20°C) (Note)

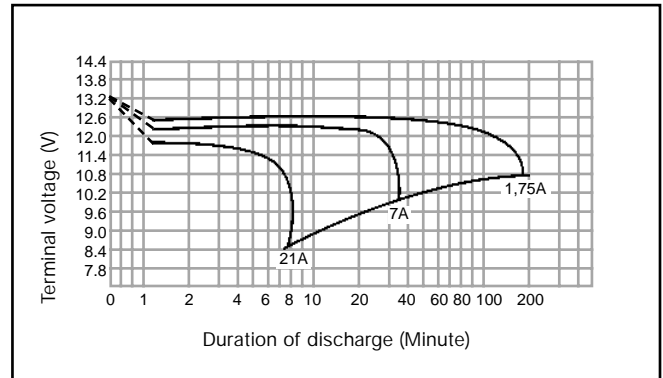

Duration of discharge vs. Discharge current (Note)

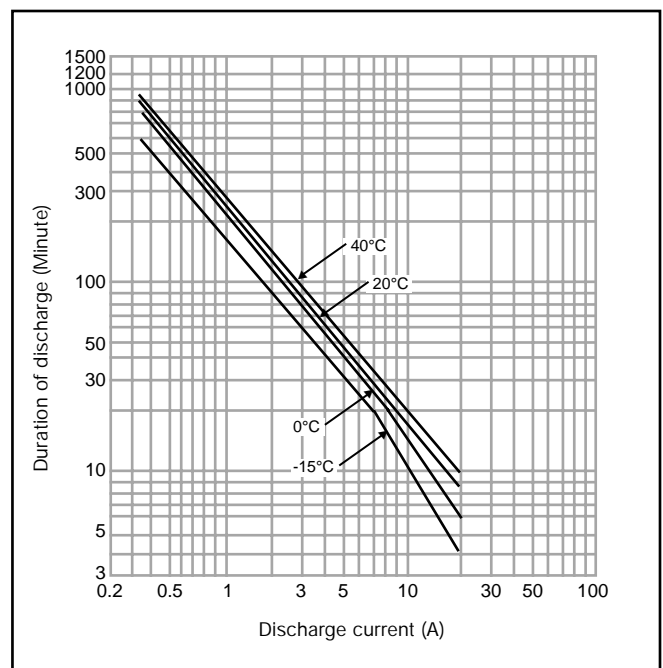

UP-RW1245P1



For standby power supplies.
Trickle Design life: 6 years at 20°C.

Dimensions (mm)

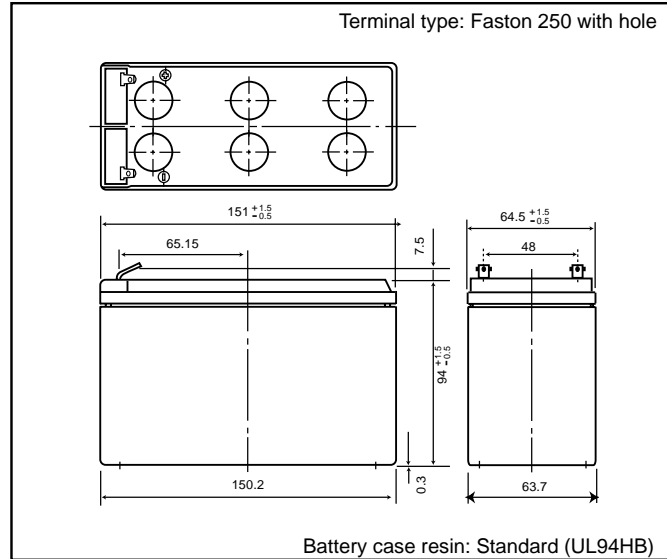

Specifications

| | | |
|-----------------------------------|--------------|----------|
| Nominal voltage | | 12V |
| Nominal capacity (10 minute rate) | | 45W/2V |
| Dimensions | Length | 151 mm |
| | Width | 64.5 mm |
| | Height | 94 mm |
| | Total Height | 101.5 mm |
| Approx. mass | | 2.6 kg |

Discharge characteristics (20°C) (Note)

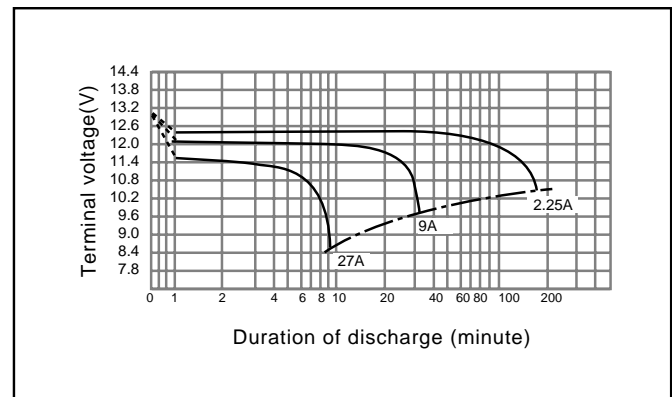

Characteristics

| | | |
|---|--|--------------|
| Capacity (note) (20°C) (9.6V Cutoff) | 30 minute rate | 108W |
| | 15 minute rate | 185W |
| | 10 minute rate | 254W |
| | 5 minute rate | 389W |
| Internal resistance | Fully charged battery (25°C) | Approx. 21mΩ |
| Temperature dependency of capacity (20 hour rate) | 40°C | 102% |
| | 20°C | 100% |
| | 0°C | 85% |
| | -15°C | 65% |
| Self discharge (20°C) | Residual capacity after standing 3 months | 91% |
| | Residual capacity after standing 6 months | 83% |
| | Residual capacity after standing 12 months | 66% |

Duration of discharge vs. Discharge current (Note)

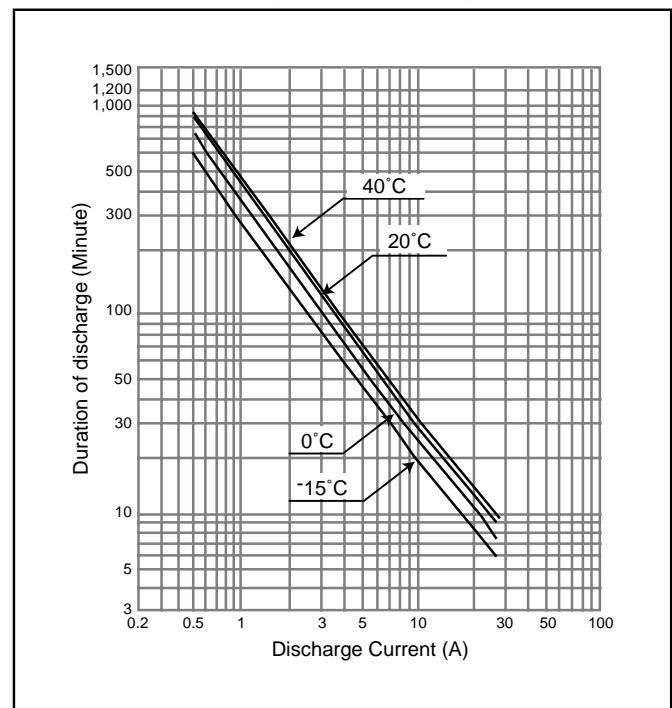

Watt Table

| Cutoff | Discharge Runtime at 20°C (unit: W) | | | | | | |
|--------|-------------------------------------|-------|-------|--------|--------|--------|--------|
| | 3 min | 5 min | 7 min | 10 min | 15 min | 20 min | 30 min |
| 9.6V | 503 | 389 | 313 | 254 | 185 | 154 | 108 |
| 10.2V | 465 | 370 | 299 | 245 | 183 | 151 | 107 |
| 10.8V | 412 | 313 | 260 | 222 | 171 | 141 | 105 |

(Note) The above characteristics data are average values obtained within three charge/discharge cycles, not the minimum values.

(Note) This battery is designed for high rate discharge and we do not specify 20 hour rate discharge capacity.

(Note) When specific conditions are satisfied, this battery can be used for main power supplies. Please consult Panasonic.

TERMINAL DATA

Terminal Data of the medium-capacity (17 to 100 Ah) battery

| Model No. | Terminal thickness A (1) | Height from battery case top | | Terminal width | Hole diameter | Hole position | | | Bolt | | | Type of Terminal |
|-----------|--------------------------|------------------------------|--------|----------------|---------------|---------------------------|---------------------------|------------------------------------|-----------------|-------|---------------|------------------|
| | | B1 (1) | B2 (2) | | | Distance from top: E1 (1) | Distance from top: E2 (2) | Distance from terminal top: E3 (2) | Diameter F1 (3) | Pitch | Length F2 (3) | |

Trickle Long Life Series

| | | | | | | | | | | | | |
|-------------|----------|----------|-----------|---------|-------------|--------|---------|----------|----|--------|----------|------------------|
| LC-RD1217P | 5.0 ±0.3 | 1.0 | - | 11 ±0.4 | 5.5 ±0.3 | 6.5 | - | 5.5 ±0.3 | M5 | P=0.8 | 15 ±1.0 | M5 bolt and nut |
| LC-RD1217AP | - | 1.7 | - | - | - | - | - | - | M5 | P=0.8 | 9.8 | M5 threaded post |
| LC-X1220P | 5.0 ±0.3 | 1.0 | - | 11 ±0.4 | 5.5 ±0.3 | 6.5 | - | 5.5 ±0.3 | M5 | P=0.8 | 15 ±1.0 | M5 bolt and nut |
| LC-X1220AP | - | 1.7 | - | - | - | - | - | - | M5 | P=0.8 | 9.8 | M5 threaded post |
| LC-X1224AP | - | 2.2 ±1.0 | 9.8 ±1.5 | - | - | - | - | - | M5 | P=0.8 | 8.3 ±1.0 | M5 threaded post |
| LC-X1224P | 8.0 ±0.5 | 4.5 | 16.5 ±1.5 | 16 ±0.8 | 6.5 ±0.4 | - | 9 ±1.0 | 7.5 ±0.4 | M5 | P=0.8 | 15 ±1.0 | M5 bolt and nut |
| LC-X1228AP | - | 2.2 ±1.0 | 9.8 ±1.5 | - | - | - | - | - | M5 | P=0.8 | 8.3 ±1.0 | M5 threaded post |
| LC-X1228P | 8.0 ±0.5 | 4.5 | 16.5 ±1.5 | 16 ±0.8 | 6.5 ±0.4 | - | 9 ±1.0 | 7.5 ±0.4 | M5 | P=0.8 | 15 ±1.0 | M5 bolt and nut |
| LC-LA1233P | 6.0 ±0.5 | - | 26.5 ±1.5 | 16 ±0.8 | 6.5 ±0.4 | - | 19 ±1.5 | 7.5 ±0.4 | M6 | P=1.0 | 20 ±1.0 | M6 bolt and nut |
| LC-X1238AP | - | 1.7 ±1.0 | 9.8 ±1.5 | - | - | - | - | - | M5 | P=0.8 | 8.3 ±1.0 | M5 threaded post |
| LC-X1238P | 8.0 ±0.5 | 5.0 | 16.5 ±1.5 | 16 ±0.8 | 6.5 ±0.4 | - | 9 ±1.0 | 7.5 ±0.4 | M6 | P=1.0 | 20 ±2.0 | M6 bolt and nut |
| LC-X1242AP | - | 1.7 ±1.0 | 9.8 ±1.5 | - | - | - | - | - | M5 | P=0.8 | 8.3 ±1.0 | M5 threaded post |
| LC-X1242P | 8.0 ±0.5 | 5.0 | 16.5 ±1.5 | 16 ±0.8 | 6.5 ±0.4 | - | 9 ±1.0 | 7.5 ±0.4 | M6 | P=1.0 | 20 ±2.0 | M6 bolt and nut |
| LC-X1265P | 7.0 ±0.5 | 2.0 ±1.0 | 18 ±1.5 | - | 6.5+0.5-0.4 | 9.5 ±1 | - | 7.5 ±0.4 | M6 | P=1.0 | 20 ±1.0 | M6 bolt and nut |
| LC-XB12100P | 8.0 ±0.5 | - | 24 ±1.5 | - | 6.5 ±0.4 | - | 14 ±1.0 | 10 ±0.4 | M8 | P=1.25 | 20 ±1.0 | M8 bolt and nut |

Cycle Long Life Series

| | | | | | | | | | | | | |
|-------------|----------|----------|-----------|---------|----------|---|--------|----------|----|-------|----------|------------------|
| LC-XC1228AP | - | 2.2 ±1.0 | 9.8 ±1.5 | - | - | - | - | - | M5 | P=0.8 | 8.3 ±1.0 | M5 threaded post |
| LC-XC1228P | 8.0 ±0.5 | 4.5 | 16.5 ±1.5 | 16 ±0.8 | 6.5 ±0.4 | - | 9 ±1.0 | 7.5 ±0.4 | M5 | P=0.8 | 15 ±1.0 | M5 bolt and nut |
| LC-XC1238AP | - | 1.7 ±1.0 | 9.8 ±1.5 | - | - | - | - | - | M5 | P=0.8 | 8.3 ±1.0 | M5 threaded post |
| LC-XC1238P | 8.0 ±0.5 | 5.0 | 16.5 ±1.5 | 16 ±0.8 | 6.5 ±0.4 | - | 9 ±1.0 | 7.5 ±0.4 | M6 | P=1.0 | 20 ±2.0 | M6 bolt and nut |

Bolt and Nut type (M5, M6, M8)

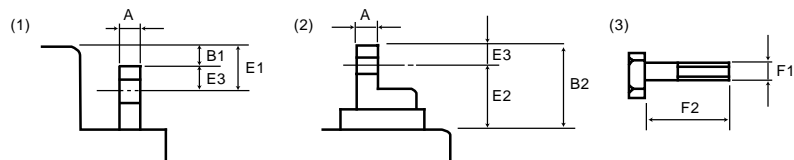

Terminal Data

Faston tab type 187

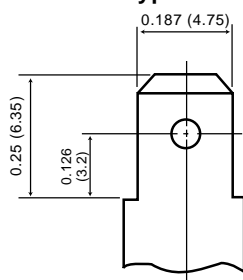

Faston type 250 Dimple

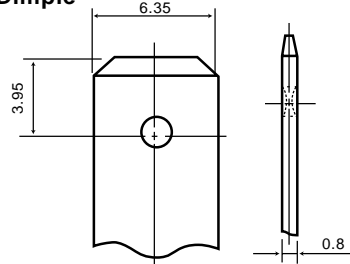

Faston tab type 250

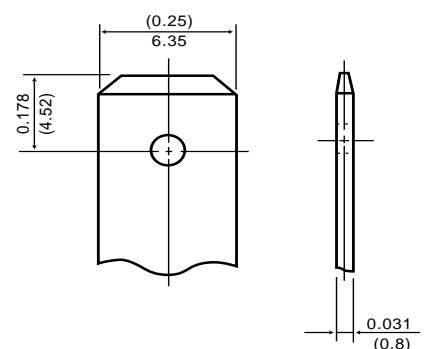

M5 threaded post type

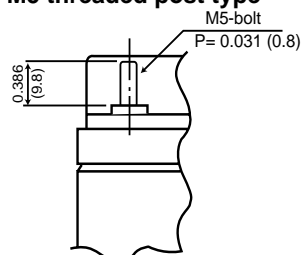

EXAMPLES OF BATTERY LABELS

The following label examples are for reference only. Label content may vary with country of manufacture and/or destination country. Please consult your local Panasonic sales office for label information on specific model numbers.

Sample of Rechargeable Valve Regulated Lead-Acid Battery Label

Panasonic

Rechargeable Valve Regulated Lead-Acid Battery

Model-No. **LC-R127R2P**
(12V, 7.2Ah/20HR)

Constant Voltage Charge

Voltage regulation

Cycle use : 14.5 - 14.9V (25°C)

(Initial current : less than 2.88A)

Standby use : 13.6 - 13.8V (25°C)

NONSPILLABLE

IN THE U.S.A. CALL 1-800-SAV-LEAD

BATTERY MUST BE RECYCLED

CAUTION

- * Do not charge in a gas tight container.
- * Do not short the battery terminals.
- * Do not incinerate.
- * Flush with water at once if contact is made with electrolyte (Acid).

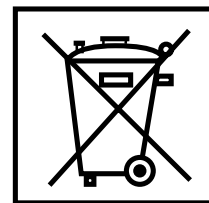

Pb

Manufactured for Matsushita Battery Industrial Co., Ltd. Osaka, Japan. Made in Mexico

GLOSSARY OF TERMS FOR VRLA-BATTERIES

Glossary of main battery terms

- | | |
|---|--|
| <ul style="list-style-type: none">● ABS RESIN A plastic material largely used for the case and cover of batteries.● ACTIVE MATERIAL The substance which electrochemically reacts in the electrode of batteries. Lead-acid batteries adopt lead dioxide for the positive electrode and spongy lead for the negative electrode.● AMBIENT TEMPERATURE Average temperature in the vicinity of the battery.● AVAILABLE CAPACITY The capacity actually available from a cell/ battery. The available capacity is the capacity of a battery when it discharges at a specified hour rate, and expressed in hour rate and Ah.● BOLT FASTENING TERMINAL A type of battery terminals, to which lead wires are connected with bolts.● BUILT-IN THERMOSTAT The built-in thermostat is a resettable switch built in a battery for temporarily cut off the battery circuit when the temperature of the battery exceeds a preset value or when the battery charges/discharges at a higher rate than predetermined.● CAPACITY The electric capability of a battery. It usually means ampere- hour capacity expressed in Ah or C (coulomb).● CELL The minimum battery unit which composes a storage battery. Nominal voltage of the cell of the lead-acid battery is 2 V.● CHARGE The operation of supplying a battery with a DC current from an external power source to have the electrode active materials conduct chemical reactions then to store electric energy as chemical energy in the battery.● CHARGE ACCEPTANCE TEST Test of batteries to check whether or not they are adequately recharged after discharge. | <ul style="list-style-type: none">● CHARGING EFFICIENCY General term for ampere-hour efficiency and watt-hour efficiency. In many cases, however, it means the ampere-hour efficiency.● CONSTANT CURRENT CHARGE A method of charging: to charge a battery with a constant current.● CONSTANT VOLTAGE CHARGE A method of charging: to charge a battery by applying a constant voltage to the terminals.● C-RATE A charge or discharge current rate expressed in A or mA. It is numerically the same as the hour rate capacity of a battery expressed in Ah of the rated capacity.● CUT-OFF VOLTAGE OF DISCHARGE The terminal voltage of a battery at which discharging should be discontinued. This voltage depends on discharge current, type of electrodes and construction of battery.● CYCLE LIFE The number of charge/discharge/rest cycles a cell/battery can provide. Cycle life is usually expressed by the number of cycles available before duration of discharge decreases to a half of the initial value.● DEPTH OF DISCHARGE A value to express the state of discharge of a battery. The depth of discharge is generally expressed by the ratio of discharge amount to rated capacity of the battery.● DISCHARGE To draw off the electric energy stored in a cell/ battery. |
|---|--|

GLOSSARY OF TERMS FOR VRLA-BATTERIES - CONTINUED

- **DISCHARGE RATE**

The term to express the magnitude of discharge current. When assuming discharge current and time to discharge cut-off voltage t hours, this discharge is called t hour rate (tHR) discharge, and the current is called t-hour rate discharge current. When time t is minutes instead of hours, tMR is used.

- **DUTY CYCLE TEST**

Test of batteries in ordinary use including charge, discharge and rest.

- **ELECTROLYTE**

The medium which serves to conduct ions in the electrochemical reactions in batteries. The lead-acid battery adopts diluted sulfuric acid as the electrolyte.

- **ENERGY DENSITY**

Energy available per unit Approx. mass or unit volume of a cell/ battery. Energy density is expressed in Wh/ kg or Wh/l.

- **FLOAT CHARGE**

The system in which a constant voltage is continuously applied to a battery connected to a rectifier in parallel with a load to maintain the battery in charged state: on occurrence of power failure or load variation, the battery supplies power to the load without any short break.

- **GAS RECOMBINATION ABILITY**

Capability of a battery to recombine (or absorb) internally generated oxygen gas at the negative plate. The greater this capability is, the larger the available charge current.

- **HIGH RATE DISCHARGE**

A very rapid discharge of a battery. (In many cases it means discharging at approx. 1 CA or higher rate.)

- **INTERNAL PRESSURE**

The pressure within a sealed battery. Internal pressure of a battery is increased by oxygen gas which is generated from the positive plate at the end of charging.

- **INTERNAL RESISTANCE**

The resistance within a battery: it is the total of individual resistances of the electrolyte and the positive and negative plates. Internal resistance is simply measured with the current four-terminal method (1,000 Hz) and expressed in the composite value of resistance component and capacitor component.

- **INTERNAL SHORT-CIRCUIT**

Touching of the positive and negative plates within a cell.

- **LIFE**

The time period until a cell/battery loses its expected characteristics.

- **LOW MAINTENANCE**

Low maintenance means that no watering nor equalizing charge is required in operating batteries.

- **LOW-VOLTAGE CUT-OFF**

A circuitry designed to discontinue discharge of a battery at a predetermined voltage level.

- **MALE TAB**

The metallic pieces which are attached to a SLA battery as the terminals.

- **MEMORY EFFECT**

A phenomenon where a temporary drop of discharge voltage is observed during deep discharge of an alkaline rechargeable battery which has been subjected to shallow charge/ discharge. Cycles or trickle charging over long time.

- **NEGATIVE PLATE**

The battery electrode into which a current from the external circuit flows during discharging. The negative plate has lower electric potential than the positive plate to the electrolyte. The negative plate is incorporated with connection parts such as the electrode pole.

- **RATED CAPACITY**

A nominal value of capacity of a cell/battery, which is a measure of electric capability. Rated capacity is rather approximate compared with rated capacity.

GLOSSARY OF TERMS FOR VRLA-BATTERIES - CONTINUED

- **NOMINAL VOLTAGE**

A nominal value to indicate the voltage of a cell battery. Generally, nominal voltage value of a battery is somewhat lower than its electromotive force. Nominal voltage of the lead-acid battery is 2.0 V per unit cell.

- **OPEN CIRCUIT VOLTAGE**

Measured voltage of a cell/battery which is electrically disconnected from the external circuit.

- **OVERCHARGE**

Continued charging of a fully charged cell/battery. With batteries which require watering, overcharge causes electrolysis of water, resulting in rapid decrease of electrolyte. Generally, overcharge adversely influences battery life.

- **OVERDISCHARGE**

Discharge of a battery to a voltage below a predetermined cut-off voltage.

- **PARALLEL CHARGE**

Simultaneous charging of two or more batteries connected in parallel. In cyclic use of batteries, specifically, the parallel charge tends to cause an imbalance in charge state among the batteries, which may shorten their service life.

- **POLYPROPYLENE RESIN**

A plastic material which is often used for the case and cover of batteries.

- **POSITIVE PLATE**

The battery electrode from which a current flows to the external circuit during discharging. The positive plate has higher electric potential than the negative plate to the electrolyte. The positive plate is incorporated with connection parts such as the electrode pole.

- **QUICK CHARGE (RAPID CHARGE)**

Charging in a short time with a large current.

- **RATED CAPACITY**

The stated capacity of a battery; namely, the ampere-hour amount which can be drawn from the battery in fully charged state at a specified temperature, at a specified discharge rate, and to a specified cut-off voltage. The symbol CN may be used to express the rated capacity of N-hour rate.

- **RECHARGEABLE BATTERY**

The rechargeable battery is a system comprising two different electrodes and an ion-conductive medium, which is capable of converting chemical energy to electric energy, and vice versa. It is also called a secondary battery.

- **REFRESH CHARGE (AUXILIARY CHARGE)**

Charging of a battery mainly to compensate for its self discharge.

- **RESIDUAL CAPACITY**

Residual capacity of a battery after partial discharge or after storage for long time.

- **RETAINER TYPE**

A method to control flowing electrolyte in a battery with the retainer mat, etc..

- **REVERSE CHARGE**

Charging of a battery with its polarity reversed. Namely, the battery discharges.

- **SELF DISCHARGE**

Reduction in capacity of a battery while no current is drawn by the external circuit. Self discharge depends on temperature: amount of discharge approximately doubles by each (10°C) rise of ambient temperature.

- **VALVE REGULATED LEAD-ACID BATTERY (VRLA-BATTERY)**

Valve regulated lead-acid battery.

- **SEPARATOR**

A porous or microporous liquid-absorbent material which is installed between the battery electrodes for preventing short-circuit, securing the separation of the electrodes and retaining electrolyte. The separator should be resistant to oxidation and chemicals; it should excel in electric insulation and liquid-retention; and it should not disturb diffusion of the electrolyte and ionic conduction.

GLOSSARY OF TERMS FOR VRLA-BATTERIES - CONTINUED

- **STANDBY USE**

General term of constant stand-by battery systems. Batteries are kept charged by trickle/float method at all times in preparation for unforeseen power disruptions.

- **TEMPERATURE COMPENSATION**

Compensation of charge voltage for temperature variation of a cell/battery or in its vicinity. Qualitatively, charge voltage should be corrected to higher side for low temperatures and to lower side for high temperatures.

- **TERMINAL VOLTAGE AT DISCHARGE**

The voltage of a battery during discharging.

- **THERMAL RUNAWAY**

Such phenomena as an excessively high set-up voltage in constant-voltage charging of a battery and a very high battery temperature cause charge current to increase, which then raises the temperature further: this vicious cycle is called thermal runaway, which may, in the worst case, result in breakage of the battery due to heat.

- **TRICKLE CHARGE**

To charge a battery in the state of disconnection from the load to compensate for its self discharge.

- **TRICKLE LIFE**

The service life of a battery in the trickle use. Usually, the trickle life is the time expressed in years before the dischargeable time of the battery decreases to a half of the initial value.

- **UL**

Abbreviation of Underwriters Laboratories Inc. in USA. The UL establishes various safety standards, and performs official recognition of materials, parts and products.

- **UPS (Uninterruptible Power Supply)**

Equipment or system which is automatically connected to the load to supply power if the main power fails.

- **VENT (ONE WAY VALVE)**

A valve on each battery which automatically releases gas from the battery when internal pressure of the battery exceeds a predetermined value: it prevents breakage of the battery due to excessive internal pressure caused by the gas generated by charging or other reasons. The valve also serves to prevent outside air from entering batteries.

For Literature and General Product Information:

United Kingdom/Ireland

Panasonic Industrial Europe GmbH
Willoughby Road
Bracknell Berkshire
RG12 8FP
England
Tel: +44 1344-853262
Fax: +44 1344-853724

Spain

Panasonic Industrial Europe GmbH
Avda. Josep Tarradellas, 20-30, 5°
08029 Barcelona - Spain
Tel: +34 93-494 92 42
Fax: +34 93-419 89 31

Italy

Panasonic Industrial Europe GmbH
Via Lucini 19
20125 Milano
Tel: +39 02-6788-232
Fax: +39 02-6788-207

France

Panasonic Industrial Europe GmbH
270 avenue du Président Wilson
93218 Saint Denis La Plaine
Tel: +33 1-49 46 44 10
Fax: +33 1-49 46 42 20

GERMANY (all other european countries)

Panasonic Industrial Europe GmbH
Winsbergring 15
22525 Hamburg
Tel: +49 40-85 386-157
Fax: +49 40-85 386-160

Website and E-mail-address for all countries:
www.panasonic-industrial.com/batteries
battery-solutions@panasonic-industrial.com

For more details, please contact:



Panasonic

Panasonic is a registered trademark of Matsushita Electric Co., Ltd.